



TEMPERATURE CONTROLLER SERIES: PR-69



INDEX

| | |
|--|----|
| 1. CATALOG DESCRIPTION | 03 |
| 2. FEATURES | 03 |
| 3. FRONT FACIA | 04 |
| 4. PRODUCT DESCRIPTION | 04 |
| 5. DIMENSIONS | 05 |
| 6. TECHNICAL SPECIFICATIONS | 06 |
| 7. EMC, SAFETY & ENVIRONMENTAL | 08 |
| 8. MEASUREMENT | 10 |
| 9. DISPLAY | 11 |
| 10. ACTIVE SET POINT SELECTION | 11 |
| 11. CONTROL STATES | 11 |
| 11.1 AUTO MATIC CONTROL (AUTO) | 11 |
| 11.2 CONTROL OFF (OFF) | 11 |
| 11.3 BUMPLESS MANUAL/OPEN LOOP CONTROL | 11 |
| 12. CONTROL ACTIONS | 11 |
| 12.1 ON/OFF CONTROL | 12 |
| 12.2 NEUTRAL ZONE ON/OFF CONTROL (nr) | 12 |
| 12.3 PID CONTROL | 12 |
| 13. AUTO TUNING | 14 |
| 14. RAMP AND SOAK | 15 |
| 14.1 POWER DOWN RESUMPTION MODE (Pwrđ) | 15 |
| 14.2 HOLDBACK (hbck) | 15 |
| 15. SOFT START | 16 |
| 16. ALARMS | 16 |
| 17. PROGRAMMING | 18 |
| 18. SEVEN SEGMENT DISPLAY | 18 |
| 19. MENUS | 18 |
| 20. MODBUS | 26 |
| 21. MODBUS QUERIES | 28 |
| 22. CONNECTION DIAGRAMS | 43 |
| 23. FAQs | 44 |

CAUTION:

1. Always follow instructions stated in this product booklet.
2. Before installation, check to ensure that specifications agree with intended application.
3. Installation must be done by skilled technician.
4. Automation and controlled devices must be properly installed so that they are protected against any risk of involuntary actuations.
5. Suitable dampers should be provided in event of excessive vibrations.

1.0 CATALOG DESCRIPTION :

Cat No: 151A12B

Description: Single acting PID controller with two relay and one SSR driving output

Cat No: 151B12B

Description: Single acting PID controller with one relay, one analog and one SSR driving Output

Cat No: 151C12B

Description: Single acting PID controller with two relay and one analog output

Cat No: 151D12B

Description: Single acting PID controller with three relay output

Cat No: 151A13B1

Description: Dual acting PID controller with two relay and one SSR driving output and RS485 Modbus communication

Cat No: 151B13B1

Description: Dual acting PID controller with one relay one analog and one SSR driving output and RS485 Modbus communication

Cat No: 151C13B1

Description: Dual acting PID controller with two relay and one analog output and RS485 Modbus communication

Cat No: 151D13B1

Description: Dual acting PID controller with three relay and RS485 Modbus communication

Note:

Models are indicated by special symbols as shown below and these symbols are used while explaining the device.

#¹ - Applicable for Cat. No. 151A12B

#² - Applicable for Cat. No. 151B12B

#³ - Applicable for Cat. No. 151C12B

#⁴ - Applicable for Cat. No. 151D12B

#⁵ - Applicable for Cat. No. 151A13B1

#⁶ - Applicable for Cat. No. 151B13B1

#⁷ - Applicable for Cat. No. 151C13B1

#⁸ - Applicable for Cat. No. 151D13B1

E.g.: coef#^{5,6,7,8} - Coefficient, Range: 0.1 to 10.0

Default: 1

The example above explains that the feature is applicable only for 151A13B1, 151B13B1, 151C13B1; 151D13B1

#symbols appear where description varies based on models. If the # does not appear, then it indicates that the feature is applicable to all the models.

2.0 FEATURES :

- Field selectable thermocouple, RTD, 0-50 mV, 0-60 mV, 12-60 mV.
- Auto tuning.
- Field configurable process and deviation alarms.
- Bump less Auto Manual transfer.
- Soft Start mode.
- °C and °F selectable.
- Dual display with configurable lower display.
- Three outputs.

Cat. Nos.: 151A12B, 151B12B, 151C12B, 151D12B:

- Control modes: ON-OFF symmetric, ON-OFF Asymmetric, Single acting PID control.
- Two set point storage.
- SSR driving with short circuit protection.

Cat. Nos.: 151A13B1, 151B13B1, 151C13B1, 151D13B1:

- Control modes: ON-OFF Symmetric, ON-OFF Asymmetric, Neutral zone ON-OFF, Single/Dual acting PID control.
- Four Set point storage.
- RS485 Modbus communication.

3.0 FRONT FACIA:

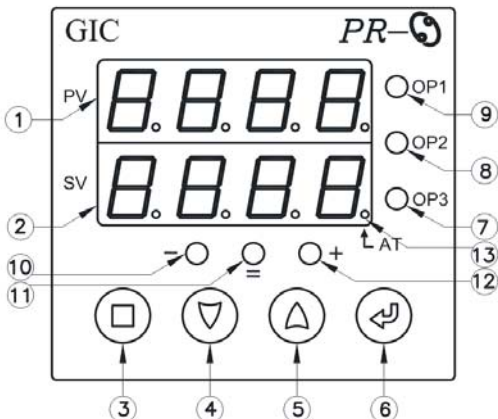

FRONT FACIA DESCRIPTION:

1. PV: Displays the "Process Value".
2. SV: Displays the "Set Value".
3. Key 'C': Configurable key.
4. Key 'DN': Scroll down key.
5. Key 'UP': Scroll up key.
6. Key 'E': Enter key.
7. oP3: LED indication for output 3.
8. oP2: LED indication for output 2.
9. oP1: LED indication for output 1.
10. '-': Indicates that PV is less than SV.
11. '=': Indicates that PV is equal to SV.
12. '+': Indicates that PV is greater than SV.
13. 'AT': This LED indicates the Auto tuning process is ON.

4.0 PRODUCT DESCRIPTION:

PR69 is a single loop, single/dual acting Microprocessor based controller with ON-OFF, PID, and auto tuning functionality. The product has two/four programmable set points and depending on model provides three different outputs. Three Input sensor accepted

1. Thermocouples
2. RTD: Pt-100 (Three wire compensation)
3. Standard mV signals: 0-50 mV, 0-60 mV, 12-60 mV.

5.0 DIMENSIONS: (in mm)

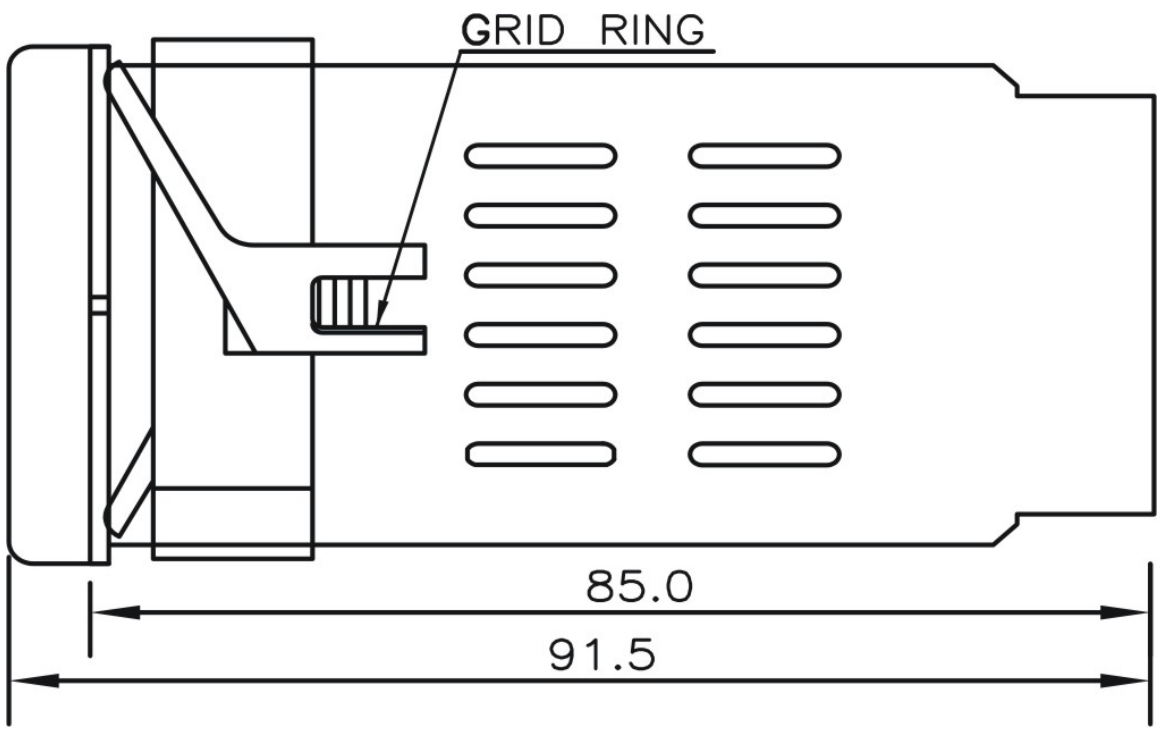
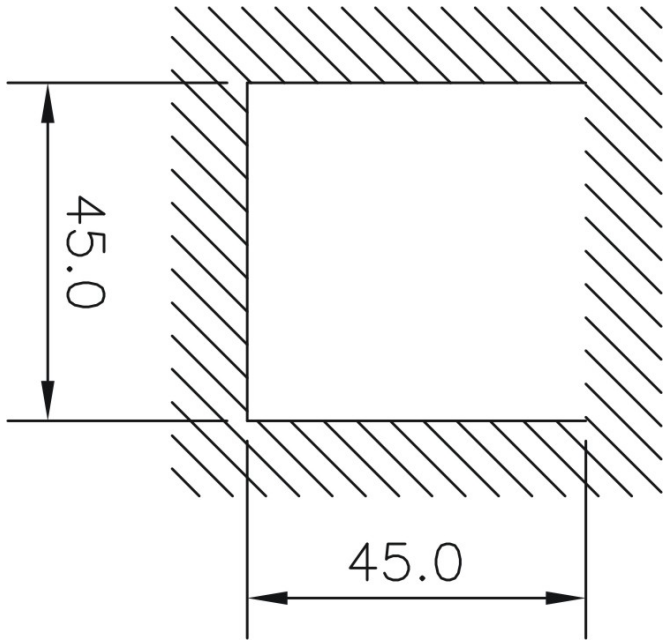

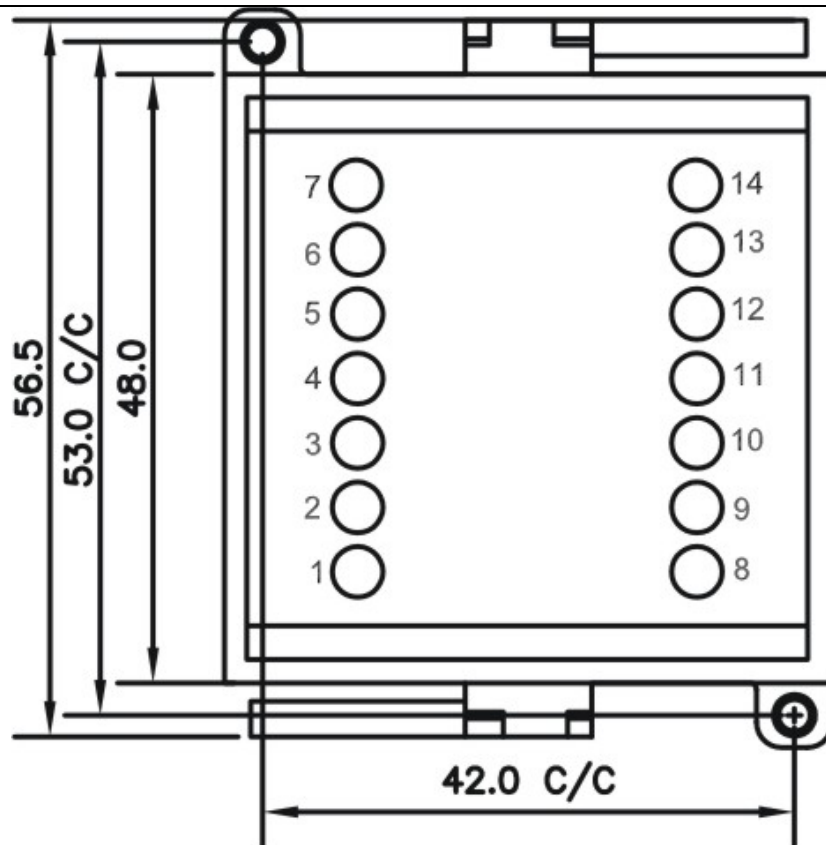

Please refer pg. 71 to pg. 74 for connection diagrams.

6.0 TECHNICAL SPECIFICATIONS:

Supply Voltage

110-240 VAC , -20% to +10%, 50-60 Hz

Power Consumption

8 VA

Temperature Sensors

J, K, E, S, B, R, Thermocouple, RTD (Pt-100,3 wire compensation), mV signals (0-50 mV,0-60 mV , 12-60 mV)

Measurement Range

Sensor J: 0 to 700°C/32 to 1292°F

Sensor K: 0 to 1300°C/32 to 2372°F

Sensor E: 0 to 600°C/32 to 1112°F

Sensor S: 0 to 1750°C/32 to 3182°F

Sensor B: 250 to 1820°C/482 to 3308°F

Sensor R: 0 to 1750°C/32 to 3182°F

Sensor Pt100: -200°C/700°C/ -328 to 1292°F

Measurement Accuracy

± 0.5 % of full scale for Pt 100, ±1% of full scale for TC and mV signals

Resolution

S, B, R,K: 1°C

J,E, Pt-100 : 0.1° C

mV: 0.001°C

Display

7 segment display -4-digit process value, 4-digit set value with LED indications

Keypad

4-Keys: UP, DN, Enter, Configurable.

oP1 rating # ^{1,4,5,8}

SPST, 8 A, 240 VAC / 28 VDC

oP1 rating # ^{2,3,6,7}

4-20 mV / 0-10 VDC

OP2 rating

SPST, 5 A, 240 VAC / 28 VDC

oP3 rating # ^{1,2,5,6}

12V, 24mA DC

oP3 rating # ^{3,4,7,8}

SPST, 5 A, 240 VAC / 28 VDC

Contact Material

Ag Alloy

Life of relays:

oP1 # ^{1,4,5,8}

Mechanical life: 1×10^7

Electrical life: 1×10^5

oP2 #

Mechanical life: 2×10^7

Electrical life: 5×10^4

oP3 # ^{3,4,7,8}

Mechanical life: 2×10^7

Electrical life: 5×10^4

Max. Resistance in case of current output (terminal 5 and 7) # ^{2,3,6,7}

600Ω

Min. Resistance in case of voltage output (terminals 6 and 7) # ^{2,3,6,7}

30 k

Temperature Sampling Rate/PID Sampling

Rate 150 ms / 1 s

Weight (Unpacked)

131 g

Humidity

93% Rh Non-Condensing

Max. Operating Altitude

2000m

Operating Temperature Range

0 to 50°C

Storage Temperature Range

-20 to 60°C

Pollution Degree

II

IP Protection

IP 54 only for front panel

Dimensions (W X H X D)

48 X 48 X 91.5 (mm)

Mounting

Panel mounting

Terminal Capacity

Screw type. 0.2-1.5 mm²

Torque

0.5 Nm

Certifications

CE, RoHS

7. EMC, SAFETY, ENVIRONMENTAL:

Product standard

IEC 61326 Ed.1 (2005-12)

ESD

IEC 61000-4-2 (2001-04) Level II

Radiated Susceptibility

IEC 61000-4-3 Ed. 1.2 (2001-04) Level III

Electrical Fast Transients

IEC 61000-4-4 Ed. 2.0 (2004-07) Level IV

Surge

IEC 61000-4-5 Ed. 2.0 (2005-11)Level IV

Conducted Susceptibility

IEC 61000-4-6 Ed.2.2 (2006-05) Level III

Voltage Dips and Interruptions

IEC 61000-4-11 (AC) Ed. 2.0(2004-11)

Conducted Emission

CISPR 14-1 Ed. 5.0 (2005-11), Class A

Radiated Emission

CISPR 14-1 Ed. 5.0 (2005-11), Class B

Isolation:

151A12B

| | Sensor | oP1 | oP2 | Op3 |
|--------|--------|------|------|------|
| Supply | 2 kV | 4 kV | 2 kV | 2 kV |
| Sensor | | 4 kV | 2 kV | NO |
| oP1 | | | 4 kV | 4 kV |
| oP2 | | | | 2 kV |

151B12B

| | Sensor | oP1 | oP2 | Op3 |
|--------|--------|------|------|------|
| Supply | 2 kV | 2 kV | 2 kV | 2 kV |
| Sensor | | NO | 2 kV | NO |
| oP1 | | | 2 kV | NO |
| oP2 | | | | 2 kV |

151C12B

| | Sensor | oP1 | oP2 | Op3 |
|--------|--------|------|------|------|
| Supply | 2 kV | 2 kV | 2 kV | 2 kV |
| Sensor | | NO | 2 kV | 2 kV |
| oP1 | | | 2 kV | 2 kV |
| oP2 | | | | 2 kV |

151D12B

| | Sensor | oP1 | oP2 | Op3 |
|--------|--------|------|------|------|
| Supply | 2 kV | 4 kV | 2 kV | 2 kV |
| Sensor | | 4 kV | 2 kV | 2 kV |
| oP1 | | | 4 kV | 4 kV |
| oP2 | | | | 2 kV |

151A13B1

| | Sensor | oP1 | oP2 | Op3 | RS485 |
|--------|--------|------|------|------|-------|
| Supply | 2 kV | 4 kV | 2 kV | 2 kV | 2 kV |
| Sensor | | 4 kV | 2 kV | NO | NO |
| oP1 | | | 4 kV | 4 kV | 4 kV |
| oP2 | | | | 2 kV | 2 kV |
| oP3 | | | | | NO |

151B13B1

| | Sensor | oP1 | oP2 | Op3 | RS485 |
|--------|--------|------|------|------|-------|
| Supply | 2 kV | 2 kV | 2 kV | 2 kV | 2 kV |
| Sensor | | NO | 2 kV | NO | NO |
| oP1 | | | 2 kV | NO | NO |
| oP2 | | | | 2 kV | 2 kV |
| oP3 | | | | | NO |

151C13B1

| | Sensor | oP1 | oP2 | Op3 | RS485 |
|--------|--------|------|------|------|-------|
| Supply | 2 kV | 2 kV | 2 kV | 2 kV | 2 kV |
| Sensor | | NO | 2 kV | 2 kV | NO |
| oP1 | | | 2 kV | 2 kV | NO |
| oP2 | | | | 2 kV | 2 kV |
| oP3 | | | | | 2 kV |

151D13B1

| | Sensor | oP1 | oP2 | Op3 | RS485 |
|--------|--------|------|------|------|-------|
| Supply | 2 kV | 4 kV | 2 kV | 2 kV | 2 kV |
| Sensor | | 4 kV | 2 kV | 2 kV | NO |
| oP1 | | | 4 kV | 4 kV | 4 kV |
| oP2 | | | | 2 kV | 2 kV |
| oP3 | | | | | 2 kV |

Note(#^{6,7}):

As there is no isolation between RS 485 and oP1, user must take care that the ground of circuits to which these outputs are connected should be isolated from each other.

Safety :**Test Voltage between I/P and O/P**

IEC 60947-5-1 Ed.3.0 (2003-11) 2 kV

Impulse Voltage between Input and Output

IEC 60947-5-1 Ed.3.0 (2003-11) Level IV

Single Fault

IEC 61010-1 Ed.2.0 (2001-02)

Insulation Resistance

UL 508 Ed.17 (1999-01) 2000 MΩ

Leakage Current

UL 508 Ed. 17 (1999-01)<3.5 mA

Environmental:**Cold Heat**

IEC 60068-2-1 Ed. 6.0 (2007-03)

Dry Heat

IEC 60068-2-2 Ed. 5.0 (2007-07)

Vibration

IEC 60068-2-6 Ed. 7.0 (2007-12) 5 g

Repetitive Shock

IEC 60068-2-27 Ed. 4.0 (2008-02), 40g, 6ms

Non-Repetitive Shock

IEC 60068-2-27 Ed. 4.0 (2008-02), 30g, 15ms

8.0 MEASUREMENT:

Parameters for this are included in the group "InP". Inputs accepted are Thermocouples (J, K, E, S, B, R) mv Signals (0-50) mV, (0-60) mV, (12-60) mV, RTD Pt100. Recommendation is to switch OFF and ON the instrument when these parameters are modified, to obtain a correct measurement. This can be through par. "unit", the unit of measurement (⁰C, ⁰F) and through parameter "dp" decimal point. In case of analog input signals, the value that instrument must visualize at the start of scale is on par. "Iscl" and the value that instrument must visualize at the end of scale is on par. (Parameter) "Isch". Instrument can be re-calibrated according to application needs, by using par. "oFst" and "rate". If "rate" = 1.000, then using par "oFst", it is possible to set positive or negative offset that is simply added to the value read by the probe.

If the offset set is not to be constant for all the measurements, it is possible to operate the calibration on any of two points. In this case, in order to decide which values to program on par. "oFst" and "rate", the following formulae must be applied:

$$\text{"rate"} = (y2-y1)/(x2-x1)$$

$$\text{"oFst"} = y2 - \text{rate} * x2$$

Where, y1 = Measured temperature 1

x1 = temperature displayed by instrument

y2 = Measured temperature 2

x2 = temperature displayed by instrument

The instrument thus visualizes the temperature as:

$$y = x * \text{"rate"} + \text{"oFst"}$$

Where y = displayed value and x = measured value.

8.1 Output in case of measurement error:

In case of measurement error (over range/under range/sensor open), the instrument supplies the power as programmed on par "oPP". In case of PID control, the power output is as a percentage of cycle time. In case of ON/OFF control, the Cycle time is automatically considered as 20 s ("e.g. In event of probe error with ON/OFF control and "oPP = 50" the control output will be activated for 10s and deactivated for 10s till measurement error remains.)

9.0 Display:

Using par. "dIsP", located in the group "conF", it is possible to configure the lower display to visualize different parameters like the control power (coP), operating set point (sP). In group "conF", the par. "LEd" is used to define the LED shift index functioning for the three LED's represented as: '+', '-', '='. The lighting up of the '=' LED indicates that the process value is within the range [sP-LEd] and [sP+LEd].

The lighting '-' LED indicates that the process value is lower than [sP-LEd] and lighting up of '+' indicates that the process value is higher than [sP+LEd]

10.0 ACTIVE SET POINT SELECTION:

For catalog no.: 151A13B1, 151B13B1, 151C13B1, 151D13B1

This instrument allows pre-programming of up to 4 different set points ("sP1", "sP2", "sP3", "sP4") and then selection of which one must be active. The maximum number of set points is determined by Par. "nsP" located in the group of parameters "sP". The effective set point can be selected:

- by parameter "EFsP" in the group of parameters "sP".
- by key "C" if par. "key" = "sPsL"

For catalog no.: 151A12B, 151B12B 151C12B,. 151D12B

This instrument allows pre-programming of up to two different set points ("sP1", "sP2") and then selection of which one must be active. The effective set point can be selected:

- by parameter "EFsP" in the group of parameters "sP".
- by key "C" if par. "key" = "sPsL"

11.0 CONTROL STATES:

The controller acts in three different ways: Automatic control (Auto), control OFF (oFF) and manual control (oPLP). By using the key "conf" on the keyboard and suitably programming par. "key" ("key" = oPLP, "key=oFF"), it is possible to pass from "Auto" state to the state programmed on the parameter and vice versa.

(The instrument switches into "Auto" state at the end of auto-tuning). When switched ON, it automatically assume its state at the last switch OFF.

11.1 Automatic Control (Auto):

Automatic control is the normal functioning state of the controller. When in Auto mode, the device will function as per parameter programmed on par. cont.

11.2 Control OFF (oFF):

In this mode, all the outputs are deactivated.

11.3 Bumpless Manual/Open Loop Control (oPLP):

This option allows to manually program the power percentage given as output by the controller by deactivating automatic control. When the instrument is switched to manual control, the power percentage is same as last one supplied. To change the power output, adjust the parameter manual reset "rs" in the "rEg" group.

12.0 CONTROL ACTIONS:

In automatic control, the controller can provide different control actions depending on the parameter "cont" in "reg" group. The different control actions are explained as below:

12.1 ON/OFF CONTROL:

All the parameters regarding ON/OFF control are listed in group "rEg". This type of control can be set by programming par. "cont"= onFs for ON-OFF action with symmetric hysteresis OR onFA for ON-OFF action with asymmetric hysteresis. It drives the output programmed as coP [selected by par. oPcF#^{5, 6, 7, 8} in oP], depending on the measured temperature value, on effective set point, function mode ("func") and on the hysteresis ("hEst").

The action can be explained as follows:

In case of reverse action i.e. HEAT being set on par. "Func" in "rEg" menu, the controller activates the output when the process value "Pv" goes below [sP-hEst]. It de-activates the output when the "Pv" goes above ["sP+hEst"] in case of symmetric ON-OFF control and above "sP" in case of Asymmetric ON-OFF control. Similarly in case of direct action i.e.

COOL being set on par. "Func", the controller activates the output when the process value "Pv" goes above (sP+hEst) and deactivates the output when "PV" goes below "SP-hEST" in case of symmetric ON-OFF control and "sP" in case of Asymmetric ON-OFF control.

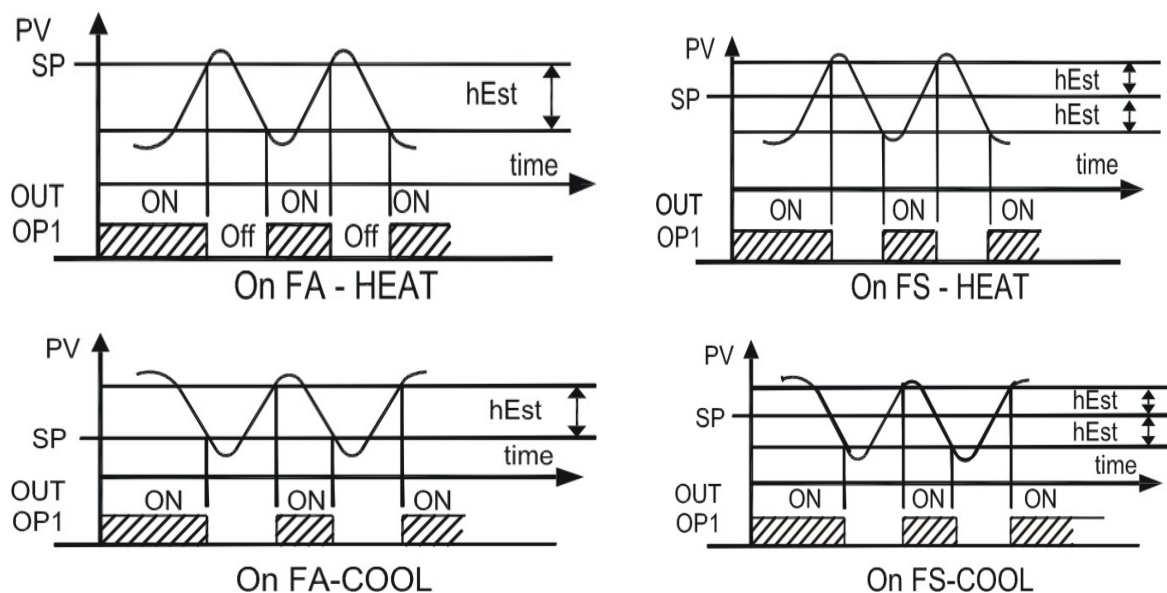

12.2 Neutral Zone ON/OFF Control (nr):

12.2.1 Action:

All the parameters referring to neutral zone ON/OFF control are listed in the group "rEg". This type of control can be set when two outputs, configured by parameter "oPcF" ("oPcF" = h1c2 configures oP1 as heater and oP2 as compressor) are programmed as "coP" and the par. "cont" = nr. The neutral zone control is used to control processes in which there is an element which causes a positive increase in temperature (eg. Heater, Humidifier etc.) And an element which causes decrease in temperature (e.g. Cooler, de-humidifier, etc.) Depending on measurements of effective set point "sP" and on

hysteresis "hEst", the control functions works on programmed outputs. The controller activates the output configured as heater when process value goes below [sP-hEst] and deactivates it once the Pv reaches sP. Further it activates the output configured on cooler when process value goes above [sP+hEst]. The cooler output is deactivated when Pv reaches sP again.

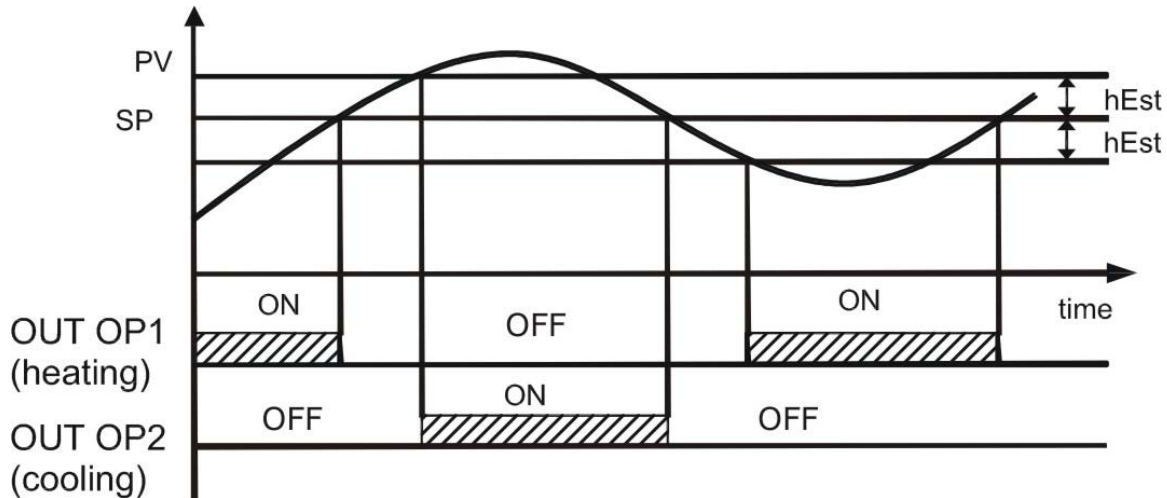

12.2.2 cdy Menu:

Compressor duty cycle "cdty" is used to protect compressor short cycling. It is a time based activation of the compressor. The activation of compressor can be avoided till the time set on parameter "cdty" thus providing the delay. Time programmed on "cdty" is counted starting from last output deactivation and then even if the regulator requires to switch on the corresponding output, the activation is delayed till the time set on "cdty" elapses.

12.3 PID Control:

12.3.0 Single Acting PID Control:

All the parameters referring to PID control are listed in the group "rEg". The single action PID control can be obtained by programming par. "cont" = Pid and works on output configured as "coP" (and selected by oPcF#^{5, 6, 7, 8} par in "oP" menu) Depending upon the effective setpoint "sP", function "FUnC" and on the instrument's PID algorithm the control output is calculated. The single action PID control algorithm foresees the setting of following parameters:

"Pb" - Proportional Band.

"Int" - Integral Time

"dEr" - derivative time

"rs" - Manual Reset (if "Int=0" only)

for #^{5,6,7,8}:

hct" - Heat output cycle time if "Func" = "hEAT"

OR "cct" - Cool output cycle time if "Func" = "cooL"

for #^{1,2,3,4}: "ct" - Cycle time

12.3.1 Double Acting PID CONTROL (#^{5,6,7,8}):

All the parameters referring to PID control are listed in the group "rEg". The double action PID control is used to control processes where there is an element which causes a positive increase in temperature (ex. Heating) and an element which causes a decrease in temperature (cooling). This type of control is selected by setting "cont" as Pid setting. At least two outputs as "coP" with oPcF parameter representing which output acts on heater and which acts on cooler. The effective set Point "sP" and the instruments algorithm decides the controller output of Double Action PID control. The cycle times "hct" (Heat cycle time: for output acting on heater) and "cct" (Cool cycle time: for output acting on cooler) should have low value with frequent intervention of control outputs so that good stability of process variable can be achieved, in case of fast processes. It is recommended to use solid state relays to drive actuators. The Double Action PID control algorithm needs the programming of following parameters:

"Pb" - Proportional Band

"hct" - Heat cycle time

"cct" - Cool cycle time

"Int" - Integral Time

"dEr" - derivative time

"rs" - Manual Reset (if "Int=0 only)

"coEF" - Coefficient Relation between power heating and cooling element. Range between 0.1 to 10.

"coEF" < 1: represents that the cooling element is stronger than heating element.

"coEF" = 1: represents that the heating and cooling element are equally strong.

"coEF" > 1: represents that the heating element is stronger than cooling element.

13.0 AUTO TUNING:

Auto tuning is a process by which the controller automatically calculates the values of dp, Int and dEr, suitable for the process. In this process, the controller carries out several operations on the process plant to determine these values.

Steps for Auto-tuning are as follows:

1. Program and select desired Set Point.

2. Program Par. "cont" =pid.

3. For single action PID control, program par. "Func" as "heat" if using heater or "COOL" if using cooler.

4. Also program the output to which the final control element is connected as "coP".

5. In case of Double action PID control, set "coP" on the two outputs selected using par. "oPcF" to act on heater and cooler.

6. Program par. "Auto" as:

"1" - Tune at Every power ON. If auto-tuning is desired, each time the instrument is switched ON.

"2" - Tune at first power ON. If auto-tuning is desired, the next time the instrument is switched ON. Once the tuning is finished, the par. "Auto" is swapped automatically to "OFF".

"3" - Tune manually. If auto-tuning is to be started manually by pressing the config key programmed as "stAt"

4"- Tune at every set point change or at the end of soft start. This activates auto-tuning at every change of set point or at the end of soft-start cycle.

7. Switch OFF the instrument power and then switch it ON to start tuning if "Auto" is set as "1" or "2" or by pressing config. key programmed as "stAt". Flashing LED AT indicates the activation of Auto-tuning function. To start the auto tune following condition needs to satisfy:

if "Func" is "HEAT"

PV < [SP - |SP/5|] if soft start is configured

OR

PV < [SP - |SP/3|] if soft start is not configured

if "Func" is "COOL"

PV > [SP + |SP/5|] if soft start is configured

OR

PV > [SP + |SP/3|] if soft start is not configured

If the above conditions are not satisfied at the start of auto tune, the display will show "ErAt" message and the instrument will take the control conditions according to previously programmed PID. To make 'ErAt' disappear Press enter key. If auto tune is not completed in 10 hours, the instrument shows 'NoAt' on display. The cycle in progress in automatically get stopped in case of sensor error. After correct PID parameters are tuned, the calculated values are stored in instrument memory.

14.0 RAMP AND SOAK #^{5,6,7,8}:

1. The PR-69 has provision for three ramps and three soaks corresponding to sP1, sP2 and sP3.
2. All parameters related to ramp functions in group 'rEg'
3. Three strategies have been adopted that determine the state of ramp and soak in case of power resumption after failure.

14.1 Power Down Resumption Mode (Prmd):

a. cont: The device keeps in memory the last set point value before the power failure. After resumption, it starts from the same value and continues the profile. In case of soak stage once the power is resumed, the stage continues for the remaining time.

b. rbck: The device starts from present Pv value and continues with the profile. In case of power failure in soak stage, once the power is resumed and if Pv is not equal to the target sP of the given soak stage, then starting from Pv the sP ramps up to the target sP value with the slope of previous ramp. Once target sP is reached, device move to soak stage which continues for the remaining time.

c. rsEt: On power failure, the entire ramp and soak profile is reset. At the end of the profile irrespective of PwrD, the device switches OFF all the control outputs.

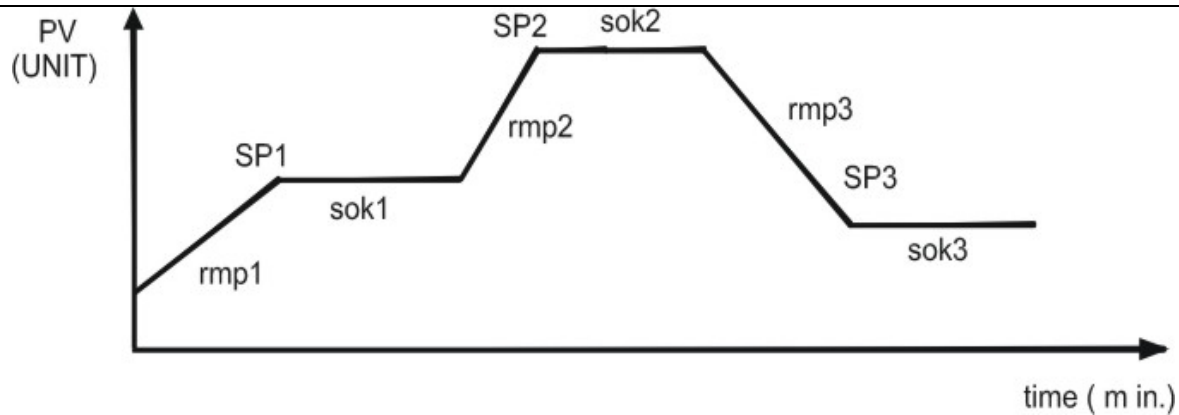

14.2 Holdback (hbck):

14.2.0 Holdback In Ramp:

While in ramp mode if the difference between SP and PV value goes beyond Holdback value, the SP ramping stops and it is held on the given value as long as $PV < (SP - hbck)$ OR $PV > (SP + hbck)$ range.

14.2.1 Holdback In Soak:

While in Soak mode if the difference between sP and Pv value goes beyond Holdback value, the soak timing is stopped and it is resumed when PV comes back within $(SP - hbck)$ and $(SP + hbck)$ range.

15.0 Soft Start :

All parameters referring to the soft start functioning are contained in the group "rEg". The soft start functioning allows limitation of output power when instrument is switched on for a limited period of time. Following parameters are needed:

"sst" - Soft start time in hh: mm

"ssth" - soft start threshold

"ssP" - soft start power

Soft start functionality will abort when sst or ssth whichever earlier is met.

16.0 ALARMS:

16.1 Alarm Types:

1. Absolute low ("AbLo" on display):

Alarm is activated if PV goes below A1th and is deactivated if PV goes above $(A1th + A1hy)$.

2. Absolute high ("Abhi" on display):

Alarm is activated if PV goes above A1th and is deactivated if PV goes below $(A1th - A1hy)$.

3. Absolute band ("Abba" on display):

Alarm is activated if PV goes above A1hi or below A1Lo. It is deactivated if it goes below $(A1hi - A1hy)$ or above $(A1Lo + A1hy)$.

4.Deviation low ("dELo" on display):

Alarm is activated if PV goes below (Effective Set Point - A1th) and is deactivated when it goes above (Effective Set Point-A1th + A1hy).

5.Deviation high("dEhi" on display):

Alarm is activated when PV goes above Effective Set Point +A1th) and is deactivated When it goes below (Effective Set Point + A1th-A1hy).

6.Deviation band ("dEbA" on display):

Alarm is activated when PV goes above (Effective Set Point + A1hi) or below (Effective Set Point - A1Lo) and is deactivated when PV goes below (Effective Set Point A1hi - A1hy) or above (Effective Set Point - A1Lo + A1hy).

7.Output low("oPLo" on display):

Alarm is activated if output goes below o1LV and deactivated when output goes above (o1LV+o1hs).

8.Output high("oPhi" on display):

Alarm is activated if output goes above o1hv and deactivated when output goes below (o1hv-o1hs).

16.2 Alarm Functions:

1. Acknowledged: -

a.+0 = Alarm not acknowledged. Alarm remains active in alarm conditions only.

b. +1 = Alarm acknowledgement active – the alarm remains active in alarm conditions and deactivated when alarm conditions does not exist. But while alarm condition still exists, if properly programmed 'C' key is pressed, then the alarm is deactivated.

2. Delayed: -

a.+0 = Alarm is activated immediately on alarm condition occurrence.

b. +2 =Alarm is activated after the delay set on par. A1dL.But, if alarm condition disappears while the controller is still executing the delay, then the alarm willnot be activated. Once activated, the alarm alarm will be deactivated only after controller sees non-alarm condition. There will be delay executed while deactivating the alarm.

3. Latched:-

A.+0 = Alarm not latched – alarm remains active in alarm conditions only.

4. No alarm at power on:

a.+0 = Alarm is activated when there are alarm conditions.

b. +8 = if the instrument is in alarm conditions when switched on, then alarm is not Activated. It will be activated once Instrument goes in non- alarm condition and back to alarm condition.

5. No alarm at sP change: -

a.+0 = alarm is activated when there are alarm condtions

b. +16 = If the instrument goes in alarm conditions after changing the set point, the alarm will not be activate. It will be activated, once instrument goes in non-alarm condition and back to alarm Condition.

Note:

Alarm types and functions are explained for Alarm 1.The explanation is same for Alarm 2.Binary addition of alarm function allows combination of different function.

E.g.

If it is required to have no alarm at power On [8] and no alarm at SP change [16], set function as 24.

17.0 PROGRAMMING:

Follow given procedure to program the device:

1. Press key 'E' to enter menus. 'PV' display shows "codE", which is blinking and 'SV' display shows "0".
2. Enter code as "69" using 'UP' key. Press key 'E' to enter into menu. If wrong code is entered, then the device exits from programming mode. If correct code is entered, the device enters into the set of menus.
3. Using 'UP' or 'DN' Key we can move to desired set of parameter.
4. Press key 'E', to enter the group of parameters related to the main menu. Here, the 'PV' display shows the menu and 'SV' shows the value programmed on it.
5. To change this value, press key 'E'. Using 'UP' or 'DN' key, select the value to be entered. Press key 'E' to confirm the value or key 'C' to maintain the previous value.
6. Whenever the value of the menu is being edited, the 'PV' display blinks. Here, 'UP' and 'DN' key change the value on 'SV' display. When the display is not blinking, we can move to next menu using 'UP' or 'DN' key. To exit from the menu press key 'C'.
7. Key 'C' acts as exit key when in programming mode. While on main screen, when 'PV' display shows temperature and 'SV' display shows user configured value, it performs the function as configured on it in the "key" parameter of "conF" menu.

18.0 SEVEN SEGMENT DISPLAY:

| | | | | | | | |
|---|---|---|---|---|---|---|---|
| A | B | C | D | E | F | G | H |
| a | b | c | d | e | f | g | h |
| I | J | K | L | M | N | O | P |
| i | j | k | l | m | n | o | p |
| Q | R | S | T | U | V | W | X |
| q | r | s | t | u | v | | |
| Y | Z | | | | | | |
| y | z | | | | | | |

19.0 MENUS:

MAIN MENU: sP (Set point)

| Parameter | Description |
|-----------|---|
| 1 | SPLL Set point low level Range: -1999 to set point active default: -1999 |
| 2 | SPhL Set point high level Range: Set point active to 9999 default: 9999 |
| 3 | nSP# ^{5,6,7,8} No. of. Set point Range: 1 to 4 default: 4 |

| | | |
|---|-------------|--|
| 4 | EFSP | Effective Set point. Range# ^{5,6,7,8} : 1 to nsP Range# ^{1,2,3,4} : 1 to 2 default: 1 |
| 5 | SP1 | Set Point 1 Range: sPLL to sPhL default: 0 |
| 6 | SP2 | Set Point 1 Range: SpLL to SphL default: 0 |
| 7 | SP3#5,6,7,8 | Set Point 3 Range: sPLL to sPhL default: 0 |
| 8 | SP4#5,6,7,8 | Set Point 4 Range: sPLL to sPhL default: 0 |

MAIN MENU: InP (Input)

| | | |
|---|------|---|
| 1 | SEnS | Sensor: Range: J - J Thermocouple K - K Thermocouple PT1 - PT100 RTD E- E Thermocouple S- S thermocouple b- b thermocouple r- r thermocouple Analog Input: 1260 12 to 60 mV 0_50 0 to 50 mV 0_60 0 to 60 mV default: Pt1 |
| 2 | IScL | Low scale in case of analog inputs Range: -1999 to Isch default: 0 |
| 3 | ISch | High scale in case of analog inputs Range: IscL to 9999 default: 100 |
| 4 | rAtE | Slope of straight line Range: 0.001 to 2.000 default: 1.000 |
| 5 | oFSt | Offset of straight line Range: -1999 to 9999 default: 0 |
| 6 | oPP | Output power in case of error Range: 0 to 100.0%# ^{1,2,3,4} Range: -100.0% to 100.0%# ^{5,6,7,8} default: 0 |
| 7 | dp | Decimal point Range: S/B/R/K thermocouple:0 |

| | | |
|----|--------------------------|--|
| | | J/E thermocouple & Pt 100:0 to 1, Analog signals: 0 to 3 default: 0 |
| 8 | unIt | Temperature measurement unit Range: °C or °F default: °C |
| 9 | rFSh# ^{2,3,6,7} | Analog signal output update rate Range: 150 to 5000 ms default: 150 ms |
| 10 | PvLo# ^{2,3,6,7} | Process variable low Range: -1999 to Pvhi Corresponds to 4 mA/0 V, default: 0 |
| 11 | Pvhi# ^{2,3,6,7} | Process variable High Range: PvLo to 9999 Corresponds to 20 mA /10 V default: 100 |
| 12 | coLo# ^{2,3,6,7} | Controller output low Range: -100.0 to cohi Corresponds to 4 mA/0 V, default: 0 |
| 13 | Cohi# ^{2,3,6,7} | Controller output high Range: coLo to 100.0 Corresponds to 20 mA/10 V, default: 100 |

MAIN MENU: oP (output)

| Parameter | | Description |
|-----------|--------------------------|--|
| 1 | OPcF # ^{6,7} | Output configure as: Range: 1. h2c3: heat 2 Cooler 3 2. h3c2: heat 3 Cooler 2 default: h2c3 |
| 1 | OPcF # ^{5,8} | Output Configure as: Range: 1.h1c2: heat 1 Cool 2 2.h1c3: heat 1 Cool 3 3.h2c3: heat 2 Cool 3 4.h2c1: heat 2 Cool 1 5.h3c1: heat 3 Cool 1 6.h3c2: heat 2 Cool 2 default: h1c2 |
| 2 | o1cF# ^{2,3,6,7} | Output 1 configured as: Range: 1. I_oP: 4-20 mA output 2. V_oP: 0-10 V output default: I_oP |
| 3 | oP1# ^{2,3} | Output 1 to act as: Range: 1. coP: Controller output 2. tEmP: Temperature default: temp |

| | | |
|---|--------------------------|---|
| 3 | oP1 # ^{6,7} | Output 1 to act as: Range: 1. coP: Controller output 2. tEmP: Temperature re-transmitted output 3.EsP: Effective Set Point re-transmitted output default: tEmP |
| 3 | oP1 # ^{1,4,5,8} | Output 1 to act as: Range: 1.coP: Controller output 2.A1no:Alarm 1 normally open 3.A1nc:Alarm 1 normally closed 4.A2no: Alarm 2 normally open 5.A2nc: Alarm 2 normally closed 6.sEnb: Sensor break 7.Brkl: Loop break alarm 8.oFF: Relay off default: oFF |
| 4 | oP2 | Output 2 to act as: Range: 1.coP: Controller output 2.A1no: Alarm 1 normally open 3.A1nc: Alarm 1 normally closed 4.A2no: Alarm 2 normally open 5.A2nc: Alarm 2 normally closed 6.Senb:Sensor break 7.Brkl:Loop break alarm 8.oFF:Relay off default: oFF |
| 5 | oP3 | Same as oP2 |
| 6 | LboP# ^{5,6,7,8} | Loop break output Lbo1# ^{5,8} : Output 1 Lbo2 : Output 2 Lbo3 : Output 3 default: Lbo2 |
| 7 | brkt | Break loop time Range: Off to 9999 s default: oFF |

MAIN MENU: AL1 (Alarm 1)

| Parameter | | Description |
|-----------|------|---|
| 1 | A1tY | Alarm 1 type Range: 1.AbLo: Absolute low 2.Abhi: Absolute high 3.AbbA: Absolute bend 4.dELo: Deviation low 5.dEhi: Deviation High 6.dEBA:Deviation band 7.oPLo: Output low 8.oPhi: Output High default: AbLo |

| | | |
|----|------|--|
| 2 | A1Fn | Alarm 1 function: +1: Acknowledge alarm +2: Delayed alarm +4: Latch alarm +8: No alarm at power on +16: No alarm at set-point change Range: 0-31 default: 0 |
| 3 | A1Lo | Alarm 1 low level Range: -1999 to A1th default: -1999 |
| 4 | A1th | Alarm 1 Threshold Range: A1Lo to A1Hi default: 0 |
| 5 | A1hi | Alarm 1 high level Range: A1th to 9999 default:9999 |
| 6 | A1hY | Alarm 1 hysteresis Range: OFF to 9999 default: 1 |
| 7 | o1LV | Output 1 low value Range# ^{1,2,3,4} :0.0%to o1HV Range# ^{5,6,7,8} : -100.0% to o1HV default: 0.0 |
| 8 | o1hV | Output 1 high value Range: o1LV to 100.0 % default: 100.0 |
| 9 | o1hs | Output 1 hysteresis Range: OFF to 100.0 % default:1 |
| 10 | A1dL | Alarm 1 delay Range: OFF to 9999 s default:OFF |

Menus for Alarm 2 are same as for Alarm 1.

MAIN MENU: REG(Regulator)

| Parameter | Description |
|-----------|--|
| 1 | cont Controller type: Range: 1.onFS:On-Off Symmetric 2.onFA:On-Off Asymmetric 3.PId: PId Controller 4.nr:neutral zone ON-OFF default: PID |
| 2 | Func Controller type: Range: 1.hEAt:Reverse acting 2.cooL:Direct acting default :hEAt |
| 3 | hEst Hysteresis for On-Off controller Range: OFF - 9999 default: 1 |

| | | |
|----|--------------------------|---|
| 4 | AUto | Auto tuning: Range: oFF: auto tuning off 1: auto tuning at every power on 2: auto tuning at first power on 3: Start manually 4: auto tune at every set point change default: 2 |
| 5 | Pb | Proportional band Range: 0 to 9999 default: 10 |
| 6 | Int | Integral time Range: OFF to 9999 s default: 120 |
| 7 | dEr | Derivative time Range: OFF to 9999 s default: OFF |
| 8 | ct# ^{1,2,3,4} | Cycle time Range: 1 to 130 s default: 20 |
| 9 | rs# ^{1,2,3,4} | Manual reset Range: 0 to 100.0 % default: 0 |
| 9 | rs# ^{5,6,7,8} | Manual reset Range: -100.0 to 100.0 % default: 0 |
| 10 | hct# ^{5,6,7,8} | heat cycle time Range: 1 to 130 s default: 20 |
| 11 | cct# ^{5,6,7,8} | Cool cycle time, Range: 1 to 130 s default: 20 |
| 12 | coeF# ^{5,6,7,8} | Coefficient, Range: 0.1 to 10.0 default: 1 |
| 13 | cdty# ^{5,6,7,8} | Compressor duty cycle Range: 0(Off) to 9999 s default: 0 |
| 14 | Prmd# ^{5,6,7,8} | Power down mode Range: 1.cont: Continue 2.rbck: Ramp back 3 rSEt: Reset default: cont |
| 15 | rmP1# ^{5,6,7,8} | Ramp 1 Range: 0.00 to 99.99 - Inf unit/min default: Inf |
| 16 | Sok1# ^{5,6,7,8} | Soak 1 Range: 0.00 to 99.59 - Inf hh:mm |

| | | |
|----|-----------------------------|---|
| | | default: Inf |
| 17 | rmP2# ^{5,6,7,8} | Ramp 2 Range: 0.00 to 99.99 - Inf unit/min default: Inf |
| 18 | Sok2# ^{5,6,7,8} | Soak 2 Range: 0.00 to 99.59 - Inf hh:mm default: Inf |
| 19 | rmP3# ^{5,6,7,8} | Ramp 3 Range: 0.00 to 99.99- Inf unit/min default: Inf |
| 20 | Sok3# ^{5,6,7,8} | Soak 3 Range: 0.00 to 99.59 - Inf hh:mm default: Inf |
| 21 | Hbck# ^{5,6,7,8} | Ramp hold back Range: OFF to 9999 default: OFF |
| 22 | SSP # ^{1,2,3,4} | Soft start power Range: 0.0 to 100.0 default: 0 |
| 22 | SSP # ^{5,6,7,8} | Soft start power Range: -100.0 to 100.0 default: 0 |
| 23 | SST | Soft start time Range: 0.00(OFF) to 7.59 (hh:mm) default: Off |
| 24 | SSTH | Soft start threshold Range: -1999 to 9999 default: 0 |

Main Menu: ConF (Configuration)

| Parameter | Description |
|-----------|---|
| 1 | Key Configurable key: Range: 1. STAT: Start tuning manually. Starts auto tuning manually if AuTo parameter is configured as 3. 2. oPLP:Open loop. Switches controller to manual mode if it is in auto mode and cont parameter is configured as PID or changes it to auto mode if it is in manual mode. 3.Ack: Acknowledge .Used to acknowledge alarm if A1Fn is in alarm acknowledge mode. Also release the alarm if is in latched mode. 4.Off: Switch off the control action |

| | | |
|---|------|---|
| | | <p>5.sLsP: select active Set point</p> <p>6.chsP:Change Set point when on main screen</p> <p>7.rsEt#^{5,6,7,8}:To Reset and restart the remp profile</p> <p>8.noFc: No function</p> <p>default :noFc</p> |
| 2 | dISP | <p>Display configure:</p> <p>Range:</p> <p>1.SP: Displays active Set point on the lower display.</p> <p>2.co:Displays controller output on the lower display</p> <p>3.EFSP #^{5,6,7,8}: Displays the Set point which is Set by EFSP</p> <p>4.A1th:Alarm 1 threshold</p> <p>5.A2th:Alarm 2 threshold</p> <p>default : sP</p> |
| 3 | LEd | <p>Led shift index</p> <p>Range :0 (off) to 9999 default:0</p> |

Main Menu: ModB (Modbus)

| | | |
|---|------|---|
| 1 | Addr | <p>Device Id</p> <p>Range: 1 to 99</p> <p>default: 1</p> |
| 2 | bAUd | <p>Baud rate:</p> <p>Range:</p> <p>1.3 : 300 baud rate</p> <p>2.6 : 600 baud rate</p> <p>3.12 : 1200 baud rate</p> <p>4.24 : 2400 baud rate</p> <p>5.48 : 4800 baud rate</p> <p>6.96 : 9600 baud rate</p> <p>7.192 : 19200 baud rate</p> <p>default :96</p> |
| 3 | Part | <p>Parity:</p> <p>Range:</p> <p>1.EvEn: Even parity</p> <p>2.Odd: Odd parity</p> <p>3.None:None parity</p> <p>default: None</p> |
| 4 | bItS | <p>No: of bits</p> <p>Range: 8 to 9</p> <p>Default: 8</p> |
| 5 | StPb | <p>No. of stop bits</p> <p>Range:1 to 2</p> <p>Default:1</p> |

20.0 MODBUS:

Pr-69 has adopted widely used MODBUS RTU protocol. The MODBUS RTU communication functions implemented in PR69 series are: function 3-Read holding variables (read); function 6-preset one word (write). These functions allow the supervisory program to read and modify any data of the controller. The communication is based on messages sent by the master station (host) to the slave stations (PR69) and vice versa. Every a message contains four fields:

- a) Slave address (from 1 to 99)
- b) Function code: contains 3 or 6 for specified functions.
- c) Information field: contains data like word addresses and word values as required by function in use.
- d) Control word: a cyclic redundancy check (CRC) performed with particular rules for CRC.

3.1 Function 3 - read n word

The request has the following frame:

| | |
|------------------------------------|------------------|
| Slave Number | Byte 0 |
| 3 | Byte 1 |
| First Word MSB Address LSB | Byte 2 Byte 3 |
| Number of Words MSB LSB | Byte 4 Byte 5 |
| CRC LSB MSB | Byte 6 Byte 7 |

The normal reply (as opposed to exception reply) has the following frame.

| | |
|-----------------------------------|----------------------|
| Slave Number | Byte 0 |
| 3 | Byte 1 |
| NB Number of Read bytes | Byte 2 |
| Value of first word MSB LSB | Byte 3 Byte 4 |
| Following Word | Byte 4 |
| CRC LSB MSB | ByteNB+2 ByteNB+3 |

3.2 Function 6 - one word write. The request has the following frame:

| | |
|------------------------------|------------------|
| Slave Number | Byte 0 |
| 6 | Byte 1 |
| Word Address MSB LSB | Byte 2 Byte 3 |
| Value to Write MSB LSB | Byte 4 Byte 5 |
| CRC LSB MSB | Byte 6 Byte 7 |

3.3 The exception reply

An exception reply is given when the request is formally correct, but cannot be satisfied standing particular situations; the reply contains a code indicating the cause of the missing regular reply The frame is:

| | |
|---|------------------|
| Slave Number | Byte 0 |
| Function code with most assign bit set to 1 | Byte 1 |
| Execution code | Byte 2 |
| CRC LSB MSB | Byte 3 Byte 4 |

- 1) Illegal Function code 1
- 2) Illegal data address 2
- 3) Illegal data value field 3
- 4) Slave device busy 6

Address 0 used for broadcasting messages has not been implemented in Pr69.

21. MODBUS QUERIES:

1. Variable - Pv

Description: Process Variable
Data type: Signed short
Range: -1999 to 9999
Decimal dependence: dP
READ/WRITE: Read
Address (in HEX) : 1001

2. Variable - coP

Description: Control Output
Data type: Signed short
Range: -100 to 100
Decimal dependence:1
READ/WRITE: Read
Address (in HEX): 1002

3. Variable - AL1

Description: Alarm 1 Status
Data type: Unsigned short
Range: OFF-xxxx xxx0, ON- xxxx xxx1
Decimal dependence: NO
READ/WRITE: Read
Address (in HEX): 1003

4. Variable - AL2

Description: Alarm 2 Status
Data type: Unsigned short
Range: OFF-xxxx xx0x, ON- xxxx xx1x
Decimal dependence: No
READ/WRITE: Read
Address (in HEX): 1003

5. Variable - SENb

Description: Sensor break alarm status
Data type: Unsigned short
Range: OFF-xxxx x0xx, ON- xxxx x1xx
Decimal dependence: No
READ/WRITE: Read
Address (in HEX): 1003

6. Variable - LbA

Description: Loop break alarm status
Data type: Unsigned short
Range: OFF-xxxx 0xxx, ON- xxxx 1xxx
Decimal dependence: No
READ/WRITE: Read
Address (in HEX): 1003

7. Variable – SP

Description: Effective set point
Data type: Signed short
Range: sPLL to sPHL
Decimal dependence: dP
READ/WRITE: Read
Address (in HEX): 1004

8. Variable - StAt

Description: Regulator status
Data type: Unsigned short
Range: OFF - 0, Manual - 1,
Decimal dependence: No
READ/WRITE: Read
AUTO SYM ON/OFF-2, AUTO ASYM ON/OFF-3,
AUTO N ZONE ON/OFF-4,
AUTO PID TUNE ON-5, AUTO PID TUNE OFF-6
Address (in HEX): 1005

9. Variable - MvEr

Description: Model Version
Data type: Unsigned short
Range: Pr01: 01, Pr02: 02, Pr03:03, Pr04: 04,Pr05: 5, Pr06: 6, Pr07: 7, PR08: 8
Decimal dependence: No
READ/WRITE: Read
Address (in HEX): 1006

10. Variable - cvEr

Description: Code Version
Data type: Unsigned short
Range: 0 to 100
Decimal dependence: No
READ/WRITE: Read
Address (in HEX): 1007

11. Variable – rFLg

Description: Ramp Soak Flg status
Range:
NO RAMP SOAK ON: 0
RAMP1 STAGE:1
SOAK1 STAGE:2
RAMP2 STAGE:3
SOAK2 STAGE:4
RAMP3 STAGE:5
SOAK3 STAGE:6
RAMP SOAK END:7
Data Type: Unsigned short
Decimal dependence: No
READ/WRITE: Read
Address(in HEX):1008

12. Variable - Aout#^{6,8}

Description: Value Transmitted on Analog output

Data type: Unsigned short

Range: 3 to 21 or 0-10

Decimal dependence: No

READ/WRITE: Read

Address (in HEX):1009

sP

1. Variable - SPL

Description: Set point low

Data type: : 'Signed' short

Range: -1999 to set point as selected by EFSP

Decimal dependence: dp

READ/WRITE: Read/Write

Address (in HEX): 2001

2. Variable - SPH

Description: Set point high

Data type: : 'Signed' short

Range: Setpoint as selected by EFSP to 9999

Decimal dependence: dP

READ/WRITE: Read/Write

Address (in HEX): 2002

3. Variable - nSP

Description: Number of set point

Data type: Signed short

Range: 1 to 4

Decimal dependence: No

READ/WRITE: Read/Write

Address (in HEX): 2003

4. Variable - EFSP

Description: Effective set point

Data type: Unsigned short

Range: 1 to nsP

Decimal dependence: No

READ/WRITE: Read/Write

Address (in HEX): 2004

Decimal dependence: dP

5. Variable - SP1

Description: Set point 1

Data type: Signed short

Range: spLL to sphL

Decimal dependence: dP

READ/WRITE: Read/Write

Address (in HEX): 2005

6. Variable - SP2

Description: Set point 2
Data type: Signed short
Range: spLL to sphL
Decimal dependence: dP
READ/WRITE: Read/Write
Address (in HEX): 2006

7. Variable - SP3

Description: Set point 3
Data type: Signed short
Range: spLL to sphL
Decimal dependence: dP
READ/WRITE: Read/Write
Address (in HEX): 2007

8. Variable - SP4

Description: Set point 4
Data type: Signed short
Range: spLL to sphL
Decimal dependence: dP
READ/WRITE: Read/Write
Address (in HEX): 2008

InP

1. Variable - SEns

Description: Sensor select
Data type: Unsigned short
Range: 0 - J thermocouple
1 - K thermocouple,
2 - E thermocouple
3 - S thermocouple
4 - B thermocouple
5 - Pt100 RTD
6 - 0-50 mV signal
7 - 0-60 mV signal
8 - 12-60 mV
9 - R thermocouple
Decimal dependence: No
READ/WRITE: Read/Write
Address (in HEX): 2009

2. Variable - IScL

Description: Analog input low
Data type: Signed short
Range: -1999 to Isch
Decimal dependence: dP
READ/WRITE: Read/Write
Address (in HEX): 200A

3. Variable - ISch

Description: Analog input high
Data type: Signed short
Range: IscL to 9999
Decimal dependence: dP
READ/WRITE: Read/Write
Address (in HEX): 200B

4. Variable - rAtE

Description: Measurement Rate
Data type: Signed short
Range: 0.001 to 2.000
Decimal dependence: dP
READ/WRITE: Read/Write
Address (in HEX): 200C

5. Variable - oFSt

Description: Measurement Offset
Data type: Signed short
Range: -1999 to 9999
Decimal dependence: dP
READ/WRITE: Read/Write
Address (in dec) : 200D

6. Variable - oPP

Description: Output power in case of error
Data type: Signed short
Range: -100.0 to 100.0
Decimal dependence: dP
READ/WRITE: Read/Write
Address (in HEX): 200E

7. Variable – dp

Description: Decimal point
Data type: Unsigned short
Range: 0 to 3
Decimal dependence: 0
READ/WRITE: Read/Write
Address (in dec) : 200F

8. Variable - unIt

Description:
Unit of measurement
Data type: Unsigned short
Range: 0 - °C, 1 - °F
Decimal dependence: No
READ/WRITE: Read/Write
Address (in HEX): 2010

9. Variable - rFSh#^{6,7}

Description: Update pace of analog output

Data type: Unsigned short
Range: 150 to 5000
Decimal dependence: No
READ/WRITE: Read/Write
Address (in HEX): 2011

10. Variable - PvLo#^{6,7}

Description: Process value/Set point low value for analog output according to value defined on oP1.

Data type: Signed short
Range: -1999 to Pvhi
Decimal dependence: dP,
READ/WRITE: Read/Write
Address (in HEX): 2012

11. Variable - Pvhi#^{6,7}

Description: Process value/Set point high value for analog output according to value defined on Op1

Data type: Signed short
Range: PvLo to 9999
Decimal dependence: dP
READ/WRITE: Read/Write
Address (in HEX): 2013

12. Variable - coLo#^{6,7}

Description: Control output low value

Data type: Signed short
Range: -100.0 to coHi
Decimal dependence: 1
READ/WRITE: Read/Write
Address (in HEX): 2014

13. Variable - Cohi#^{6,7}

Description: Control output high value

Range: CoLo to 100.0
Decimal dependence: 1
READ/WRITE: Read/Write
Address (in HEX): 2015

1. Variable - oPcF#^{5,8}

Description: Output Configure

Data type: Unsigned short
Range: 0: H1C2, 1: H1C3, 2: H2C1, 3: H3C1,
4: H2C3, 5: H3C2

Decimal dependence: No
READ/WRITE: Read/Write
Address (in HEX): 2016

1. Variable - oPcF#^{6,7}

Description: Output Configure

Data type: Unsigned short
Range: 0: H2C3, 1: H3C2
Decimal dependence: No

READ/WRITE: Read/Write
Address (in HEX): 2016

2. Variable - o1cF#^{6,7}

Description: Output 1 Config
Data type: Unsigned short
Range: 0: I_oP, 1: V_oP
Decimal dependence: No
READ/WRITE: Read/Write
Address (in HEX):2017

3. Variable - oP1#^{6,7}

Description:Output1 act on
Data type: Unsigned short
Range: 0: coP, 1: temp
Decimal dependence: No
READ/WRITE: Read/Write
Address (in HEX): 2018

4. Variable - oP1#^{5,8}

Description:Output1 act on
Data type: Unsigned short
Range: 0: coP, 1: A1no, 2: A1nc, 3: A2no, 4: A2nc,
5: Senb, 6: BrkL, 7: Off
Decimal dependence: No
READ/WRITE: Read/Write
Address (in HEX):2018

5. Variable - oP2

Description: Output 2 act on
Data type: Unsigned short
Range: 0: coP, 1: A1no, 2: A1nc, 3: A2no,4: A2nc,
5: Senb, 6: BrkL, 7: Off
Decimal dependence: No
READ/WRITE: Read/Write
Address (in HEX):2019

6. Variable - oP3

Description: Output 3 act on
Data type: Unsigned short
Range: 0: coP, 1: A1no, 2: A1nc, 3: A2no, 4: A2nc,
5: Senb, 6: BrkL, 7: Off
Decimal dependence: No
READ/WRITE: Read/Write
Address (in HEX): 201A

7. Variable - LboP

Description: Loop break alarm act on
Data type: Unsigned short
Range: 0: Lbo1#^{5,8}, 1: Lbo2, 2: Lbo3, 0: Lbo2, 1: Lbo3#⁶⁷
Decimal dependence: No
READ/WRITE: Write
Address (in HEX): 201B

8. Variable - brkt

Description: Loop Break time

Data type: Unsigned short

Range: 0 to 9999

Decimal dependence: No

READ/WRITE: Read/Write

Address (in HEX): 201C

Alarms Types :

1. Variable - A1tY

Description: Alarm 1 type

Data type: Unsigned short

Range: 0: AbLo, 1: AbHi, 2: AbbA, 3: dELo, 4: dEHi,

5: dEbA, 6: oPLo, 7: oPHi

Decimal dependence: No

READ/WRITE: Read/Write

Address (in HEX): 201D

2. Variable - A1Fn

Description: Alarm 1 Function

Data type: Unsigned short

Range: 0 to 31

Decimal dependence: 0

READ/WRITE: Read/Write

Address (in HEX): 201E

3. Variable - A1Lo

Description: Alarm 1 Function

Data type: Signed short

Range: -1999 to A1th

Decimal dependence: dP

READ/WRITE: Read/Write

Address (in HEX): 201F

4. Variable - A1th

Description: Alarm 1 Function

Data type: Signed short

Range: A1Lo to A1hi

Decimal dependence: dP

READ/WRITE: Read/Write

Address (in HEX): 2020

5. Variable - A1hi

Description: Alarm 1 High

Data type: Signed short

Range: A1th to 9999

Decimal dependence: dP

READ/WRITE: Read/Write

Address (in HEX): 2021

6. Variable - A1hY

Description: Alarm 1 hysteresis
Data type: Unsigned short
Range: 0 to 9999
Decimal dependence: dP
READ/WRITE: Read/Write
Address (in HEX): 2022

7. Variable - o1Lv

Description: Output Low alarm1 value
Data type: Signed short
Range: -100.0 to o1HV
Decimal dependence: 1
READ/WRITE: Read/Write
Address (in HEX): 2023

8. Variable - o1hv

Description: Output high alarm1 value
Data type: Signed short
Range: o1LV to 100.0
Decimal dependence: 1
READ/WRITE: Read/Write
Address (in HEX): 2024

9. Variable - o1hs

Description: Output alarm hysteresis 1
Data type: Unsigned short
Range: OFF to 100.0
Decimal dependence: 1
READ/WRITE: Read/Write
Address (in HEX): 2025

10. Variable - A1dL

Description: Alarm 1 delay
Data type: Unsigned short
Range: OFF to 9999
Decimal dependence: 0
READ/WRITE: Read/Write
Address (in HEX): 2026

AL2

1. Variable - A2tY

Description: Alarm 2 type
Data type: Unsigned short
Range: 0: AbLo, 1: AbHi, 2: AbbA, 3: dELo
4: dEHi, 5: dEbA, 6: oPLo, 7: oPHi
Decimal dependence: No
READ/WRITE: Read/Write
Address (in HEX): 2027

2. Variable - A2Fn

Description: Alarm 2 Function
Data type: Unsigned short
Range: 0 to 31
Decimal dependence: 0
READ/WRITE: Read/Write
Address (in HEX): 2028

3. Variable - A2Lo

Description: Alarm 2 Function
Data type: Signed short
Range: -1999 to A2th
Decimal dependence: dP
READ/WRITE: Read/Write
Address (in HEX): 2029

4. Variable - A2Th

Description: Alarm 2 Function
Data type: Signed short
Range: A2Lo to A2hi
Decimal dependence: dP
READ/WRITE: Read/Write
Address (in HEX): 202A

5. Variable - A2hI

Description: Alarm 2 High
Data type: Signed short
Range: A2th to 9999
Decimal dependence: dP
READ/WRITE: Read/Write
Address (in HEX): 202B

6. Variable - A2hY

Description: Alarm 2 hysteresis
Data type: Unsigned short
Range: 0 to 9999
Decimal dependence: dP
READ/WRITE: Read/Write
Address (in HEX): 202C

7. Variable - o2Lv

Description: Output Low alarm1 value
Data type: Signed short
Range: -100.0 to o1Hv
Decimal dependence: 1
READ/WRITE: Read/Write
Address (in HEX): 202D

8. Variable - o2hv

Description: Output high alarm 2 value
Data type: Signed short

Range: 0.1LV to 100.0
Decimal dependence: 1
READ/WRITE: Read/Write
Address (in HEX): 202E

9. Variable - o2hs

Description: Output alarm hysteresis 2
Data type: Unsigned short
Range: OFF to 100.0
Decimal dependence: 1
READ/WRITE: Read/Write
Address (in HEX): 202F

10. Variable - A2dL

Description: Alarm 2 delay
Data type: Unsigned short
Range: OFF to 9999
Decimal dependence: 0
READ/WRITE: Read/Write
Address (in HEX): 2030

rEg

1. Variable - Cont

Description: Control type
Data type: Unsigned short
Range: 0: onFS, 1: onFA, 2: Pid, 3: nr
Decimal dependence: No
READ/WRITE: Read/Write
Address (in HEX): 2031

2. Variable - Func

Description: Control action functioning
Data type: Unsigned short
Range: 0: HEAt, 1: cool
Decimal dependence: No
READ/WRITE: Read/Write
Address (in HEX): 2032

3. Variable - hEst

Description: On Off Hysteresis
Data type: Unsigned short
Range: 0 to 9999
Decimal dependence: No
READ/WRITE: Read/Write
Address (in HEX): 2033

4. Variable - Auto

Description: Auto tune
Data type: Unsigned short
Range: 0: Off, 1: 1, 2: 2, 3: 3, 4: 4
Decimal dependence: No
READ/WRITE: Read/Write

Address (in HEX): 2034

5. Variable - Pb

Description: Proportional Band

Data type: Unsigned short

Range: 0 to 9999

Decimal dependence: 0

READ/WRITE: Read/Write

Address (in HEX): 2035

6. Variable - Int

Description: Integral time

Data type: Unsigned short

Range: 0 to 9999

Decimal dependence: 0

READ/WRITE: Read/Write

Address (in HEX): 2036

7. Variable - dEr

Description: Derivative time

Data type: Unsigned short

Range: 0 to 9999

Decimal dependence: 0

READ/WRITE: Read/Write

Address (in HEX): 2037

8. Variable - rs

Description: Manual reset

Data type: Signed short

Range: -100 to 100

Decimal dependence: 1

READ/WRITE: Read/Write

Address (in HEX): 2038

9. Variable - hct

Description: Heater output cycle time

Data type: Unsigned short

Range: 1 to 130

Decimal dependence: 0

READ/WRITE: Read/Write

Address (in HEX): 2039

10. Variable - cct

Description: Cooler output cycle time

Data type: Unsigned short

Range: 1 to 130

Decimal dependence: 0

READ/WRITE: Read/Write

Address (in HEX): 203A

11. Variable - coEF

Description: Coefficient

Data type: Unsigned short

Range: 0.1 to 10.0
Decimal dependence: 1
READ/WRITE: Read/Write
Address (in HEX): 203B

12. Variable - cdtY

Description: Compressor On delay time
Data type: Signed short
Range: 0 to 9999
Decimal dependence: 0
READ/WRITE: Read/Write
Address (in HEX): 203C

13. Variable - Prmd

Description: Power down resume mode
Data type: Unsigned short
Range: 0:Cont , 1: rbcK, 2: rsEt
Decimal dependence: No
READ/WRITE: Read/Write
Address (in HEX): 203D

14. Variable - rmP1

Description: Ramp 1
Data type: Unsigned short
Range: 0 to 99.99
Decimal dependence: 2
READ/WRITE: Read/Write
Address (in HEX): 203E

15. Variable - rmP2

Description: Ramp 2
Data type: Unsigned short
Range: 0 to 99.99
Decimal dependence: 2
READ/WRITE: Read/Write
Address (in HEX): 203F

16. Variable - rmP3

Description: Ramp 3
Data type: Unsigned short
Range: 0 to 99.99
Decimal dependence: 2
READ/WRITE: Read/Write
Address (in HEX): 2040

17. Variable - Sok1

Description: Soak 1
Data type: Unsigned short
Range: 0 to 99.59(hour:min)
Decimal dependence: 2
READ/WRITE: Read/Write
Address (in HEX): 2041

18. Variable - Sok2

Description: Soak 2
Data type: Unsigned short
Range: 0 to 99.59 (hour: min)
Decimal dependence: 2
READ/WRITE: Read/Write
Address (in HEX): 2042

19. Variable - Sok3

Description: Soak 3
Data type: Unsigned short
Range: 0 to 99.59(hour:min)
Decimal dependence: 2
READ/WRITE: Read/Write
Address (in HEX): 2043

20. Variable - hbck

Description: Ramp Hold back
Data type: Unsigned short
Range: 0 to 9999
Decimal dependence: dP
READ/WRITE: Read/Write
Address (in HEX): 2044

21. Variable - ssP

Description: Soft start Power
Data type: Unsigned short
Range: -100 to 100
Decimal dependence: 1
READ/WRITE: Read/Write
Address (in HEX): 2045

22. Variable - sst

Description: Soft start time
Data type: Unsigned short
Range: 0 to 7:59
Decimal dependence: 0
READ/WRITE: Read/Write
Address (in HEX): 2046

23. Variable - ssth

Description: Soft start threshold
Data type: Signed short
Range: -1999 to 9999
Decimal dependence: 0
READ/WRITE: Read/Write
Address (in HEX): 2047

Conf**1. Variable - Key**

Description: Configure Key

Data type: Unsigned short
Range: 0: STAT, 1: oPLP, 2: Ack, 3: oFF,
4: SISP, 5: ChSP, 6: rSEt, 7: noFc
Decimal dependence: No
READ/WRITE: Read/Write
Address (in HEX): 2048

2. Variable - disp

Description: Configure Display
Data type: Unsigned short
Range: 0: SP, 1: Co, 2:A1th, 3: A2th,4:EFSp.
Decimal dependence: No
READ/WRITE: Read/Write
Address (in HEX): 2049

3. Variable - Led

Description: Led Compare Index
Data type: Unsigned short
Range: 0 to 9999
Decimal dependence: dP
READ/WRITE: Read/Write
Address (in HEX): 204A

22. CONNECTION DIAGRAMS:

151A12B

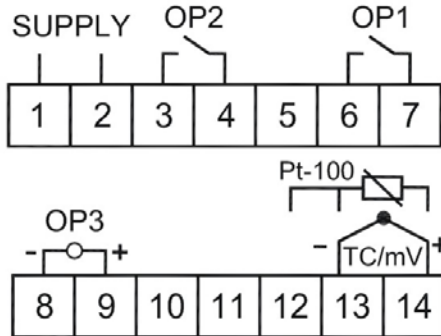

151C12B

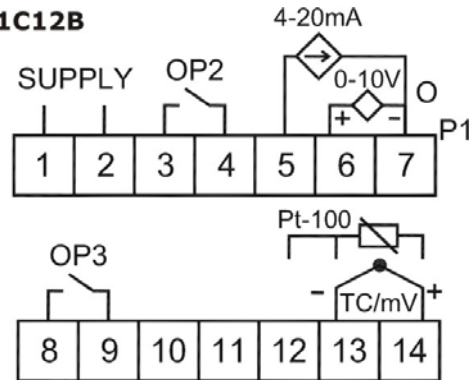

151B12B

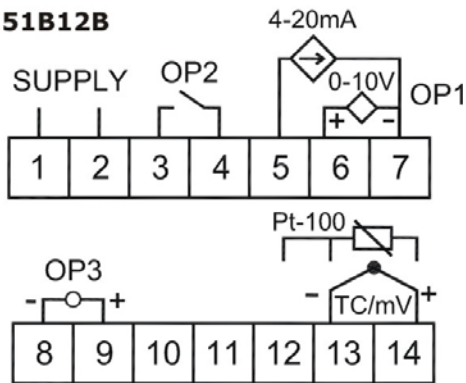

151D12B

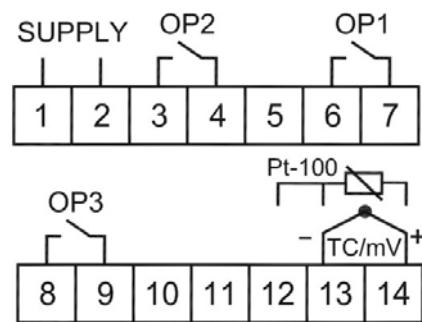

151A13B1

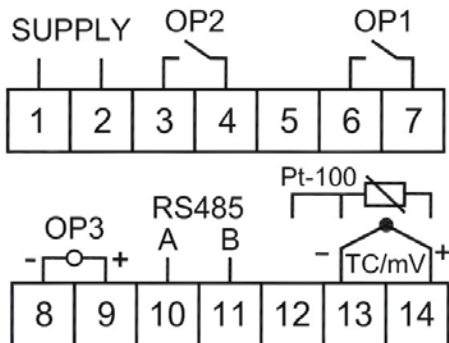

151C13B1

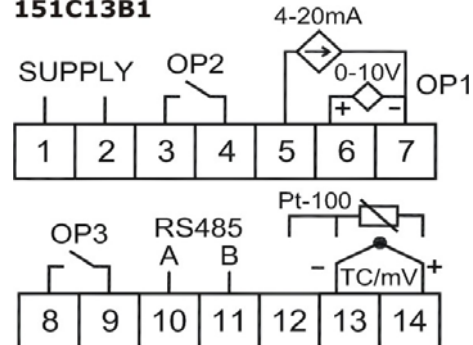

151B13B1

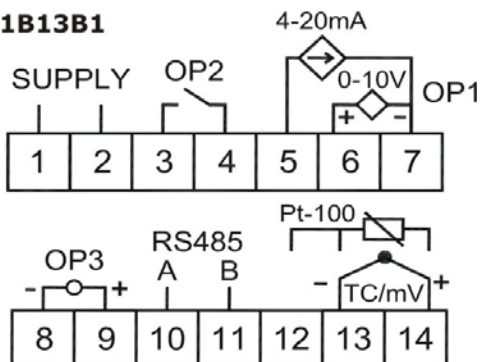

151D13B1

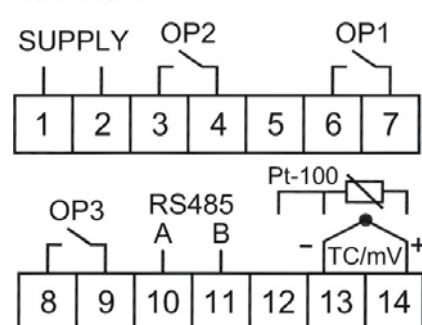

23. FAQs :

1. How to change effective set point selection using key 'C'?

A. "sLsP" (select effective set point) must be programmed on "key" parameter in the "conf" menu. If 'C' key is pressed and held for 3 s while on main screen "EFsP" is displayed on the upper display and currently effective set point (1 if sP1 is effective and 2 if sP2 is effective) is displayed on the lower display. The upper display starts blinking. Using 'UP' /'DN' key the value can be changed. Press 'E' to activate the set point. Upper display stops blinking. Press 'C' key to exit from menu to main screen.

2. What is 'rAtE' and 'oFst' parameter in the 'Inp' menu?

A.If it is required to apply slope and/or offset to the temperature measured by the instrument, it can be done by using the above parameters. Any value set on above parameter allows the device to see temperature as below: Display temp. = rAtE* Measured Temp + oFst

This helps to re-calibrate the instrument.

3. What is "Sens" Break alarm and break loop alarm?

A.To select sensor break alarm set "sEnb" on the desired output. Whenever sensor, break error occurs, the corresponding relay is set. To select break loop alarm, break loop alarm time i.e. "Brkt" is to be set. If the controller output remains at 100% for the above time, then loop break alarm is given. If any relay output is set for the alarm, the given relay is switched on. Break loop alarm works only in PID mode. Break loop alarm can be turned off by moving the controller to OFF mode and then back to auto mode by pressing properly programmed 'C' key.

4. What is soft start threshold and soft start time?

A.Soft start time is the time for which the soft power is provided after On. Soft start threshold is the absolute temperature upto which soft power is provided. While in soft start, if any of the above value is reached, the soft start ends.

5. How to start auto tuning?

A. Depending on the value programmed on the parameter "Auto" in "rEG" group auto tuning can be started.

1: Auto tuning is started at every power ON of the instrument.

2: Auto tuning is started at first power ON of the instrument.

3: Auto tuning can be started manually by the user by pressing properly programmed 'C' key.

4: Auto tuning is started at every set point change. The set point changed should be the effective point. Even if the value on parameter "EFsP" in the "sP" menu is changed and the values parameter "sP1" and "sP2" in the menu are different, the auto tuning is started. Following condition must be satisfied to start auto tune:

Controller should be in PID mode.

If soft start is configured and auto tune is on

1 or 2 or 4:

"sP" be set the on $PV < (sP - |sP/5|)$ for HEAT action.

or $PV > (sP + |sP/5|)$ for COOL action.

In all other conditions:

$PV < (sP - |sP/3|)$ for HEAT action or

$PV > (sP + |sP/3|)$ for COOL action

6. What value will be returned by the device if a read query for the PV is sent and the device has Sensor/Over/Under range error?

A. Following values will be sent as reply for the modbus query to read temperature if device is in error mode

| Error displayed | Value returned |
|-------------------------|----------------|
| SEnb (sensor open) | 0xC000 |
| ovrg (over range error) | 0xC001 |
| unrg(under range error) | 0xC002 |

7. How to restart ramp and soak profile?

A.To restart the ramp soak profile program 'C' key as "rsEt", then while on the main screen press and hold the key for about 3 s. When reset, the lower display alternates between a message "rsEt" and value configured on it by the user. This message disappears after a time of about 1 min.

8. How to change Set point while on main Screen?

A. It is possible to change the set point while on main screen. For this set "key" parameter in "conF" menu as "chsP". Then any time when on main screen if the "C" key is pressed for more than 3 sec currently effective set point appears on the screen. The upper display start blinking. By using "up" key or "down" key the value can be changed. Press "E" key to save the value. To discard the value press "C" key. To exit to main screen, press "C" key.

9. How to read SPLL value through Modbus?

A. The query structure of read query is explained earlier Assume that Slave address is 01

| | |
|--------------------|----|
| Slave Number | 01 |
| 3 (Function Code) | 03 |
| First Word Address | |
| MSB | 20 |
| LSB | 01 |
| Number of Words | |
| MSB | 00 |
| LSB | 01 |
| CRC | |
| LSB | DE |
| MSB | 0A |

