

AI808 Series Intelligent Temperature Controller User Manual



Features:

- ⊙ TC / RTD / Analog signal universal input, selected by software menu.
- ⊙ With display, alarm and adjusting function
- ⊙ Advanced Fuzzy algorithm & Two Degrees of Freedom PID Arithmetic.
- ⊙ Optional control output, modularization design.
- ⊙ Good anti-jamming.
- ⊙ Up to 50 program stages control.

For your safe, please read the below content carefully before you use the temperature controller!

■ Safe Caution

※	Please read the manual carefully before you use the temperature controller.
※	Please comply with the below important points.
⚠	Warning An accident may happen if the operation does not comply with the instruction.
⚠	Notice An operation that does not comply with the instruction may lead to product damage.
※	The instruction of the symbol in the manual is as below.
⚠	An accident danger may happen in a special condition.

⚠ Warning

1. A safety protection equipment must be installed or please contact with us for the relative information if the product is used under the circumstance such as nuclear control, medical treatment equipment, automobile, train, airplane, aviation and equipment etc.. Otherwise, it may cause serious loss, fire or person injury.
2. A panel must be installed, otherwise it may cause creepage (leakage).
3. Do not touch wire connectors when the power is on, otherwise you may get an electric shock.
4. Do not dismantle or modify the product. If you have to do so, please contact with us first. Otherwise it may cause electric shock and fire.
5. Please check the connection number while you connect the power supply wire or input signal, otherwise it may cause fire.

⚠ Caution

1. This product cannot be used outdoors. Otherwise the working life of the product will become shorter, or an electric shock accident may happen.
2. When you connect wire to the power input connectors or signal input connectors, the moment of the No.20 AWG (0.50 mm²) screw tweaked to the connector is 0.74n.m - 0.9n.m. Otherwise the connectors may be damaged or get fire.
3. Please comply with the rated specification. Otherwise it may cause electric shock or fire, and damage the product.
4. Do not use water or oil base cleaner to clean the product. Otherwise it may cause electric shock or fire and damage the product.
5. This product should be avoid working under the circumstance that is flammable, explosive, moist, under sunshine, heat radiation and vibration. Otherwise it may cause explosion.
6. In this unit it must not have dust or deposit, otherwise it may cause fire or mechanical malfunction.
7. Do not use gasoline, chemical solvent to clean the cover of the product because such solvent can damage it. Please use some soft cloth with water or alcohol to clean the plastic cover.

1. Model

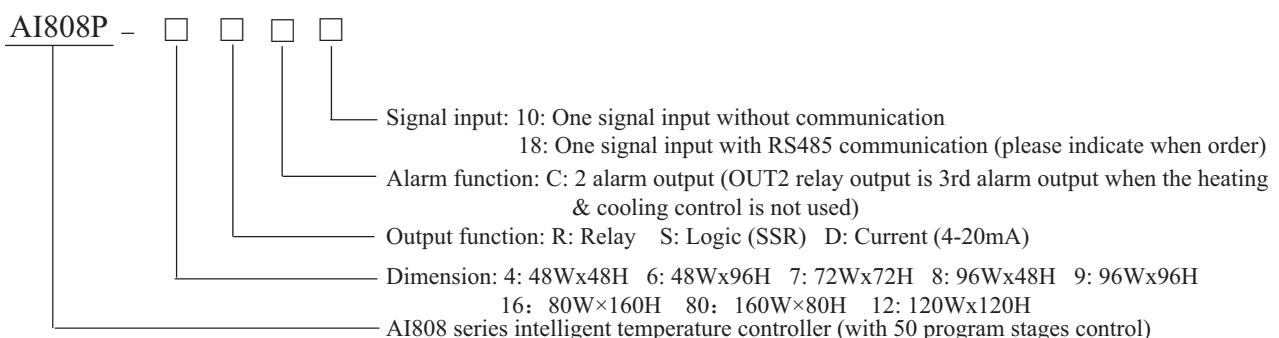

2. Model Indication

Model	Alarm no.	OUT1	OUT2	Communication
AI808P-□RC10	2	Relay output	Relay output	No
AI808P-□SC10	2	SSR output	Relay output	No
AI808P-□DC10	2	4-20mA current output	Relay output	No
AI808P-□RC18	2	Relay output	Relay output	RS485 (Modbus RTU)
AI808P-□SC18	2	SSR output	Relay output	RS485 (Modbus RTU)
AI808P-□DC18	2	4-20mA current output	Relay output	RS485 (Modbus RTU)

3. Main Technical Parameters

1) Whole controller parameters

Power supply	100-240VAC
Total current	<30mA (220VAC)
Ambient temperature	0-50℃
Ambient humidity	45-85%RH
Measurement accuracy	0.3%FS±3digits 25℃
Control mode	ON/OFF control, PID heating control, PID cooling control, PID heating & cooling control
Communication function	RS485 communication interface, MODBUS protocol
Panel protection level	IP65
Temperature excursion	≤0.01%FS/℃
Dielectric strength	Between the connectors of power supply to relay output, power supply to signal input, relay output to signal input ≥2000VDC; Between the low voltage signal isolated with each other ≥600VDC.
OUT1	4-20mA current output, load resistance 600Ω max.
	Relay output capacity: 3A/230Vac
	SSR output capacity: 30mA/24Vdc
OUT2	Relay output capacity: 3A/230Vac.
Alarm	Relay output capacity: 1A/230Vac

2) Input signal table

Signal	Input type	Measuring range	Resolution	Input impedance
K	K type thermocouple	-50~1300℃	1℃	>100KΩ
J	J type thermocouple	-50~1200℃	1℃	>100KΩ
E	E type thermocouple	-50~1000℃	1℃	>100KΩ
t	T type thermocouple	-50~400℃	1℃	>100KΩ
b	B type thermocouple	600~1800℃	1℃	>100KΩ
r	R type thermocouple	-10~1700℃	1℃	>100KΩ
S	S type thermocouple	-10~1600℃	1℃	>100KΩ
n	N type thermocouple	-50~1200℃	1℃	>100KΩ
□E□	Reserved			
Pt	PT100	-199.9~850.0℃	0.1℃	(0.2mA)
JPt	JPT100	-199.9~500.0℃	0.1℃	(0.2mA)
CU50	CU50	-50.0~150.0℃	0.1℃	(0.2mA)
CU100	CU100	-50.0~150.0℃	0.1℃	(0.2mA)
V	Linear voltage	0~50mV	0.01%FS	>100KΩ
I	Linear current	4~20mA	0.01%FS	<110Ω
V	Linear voltage	0~10V	0.01%FS	>100KΩ
Rt	Linear resistance	0~400Ω	0.01%FS	(0.2mA)

4. Panel indication

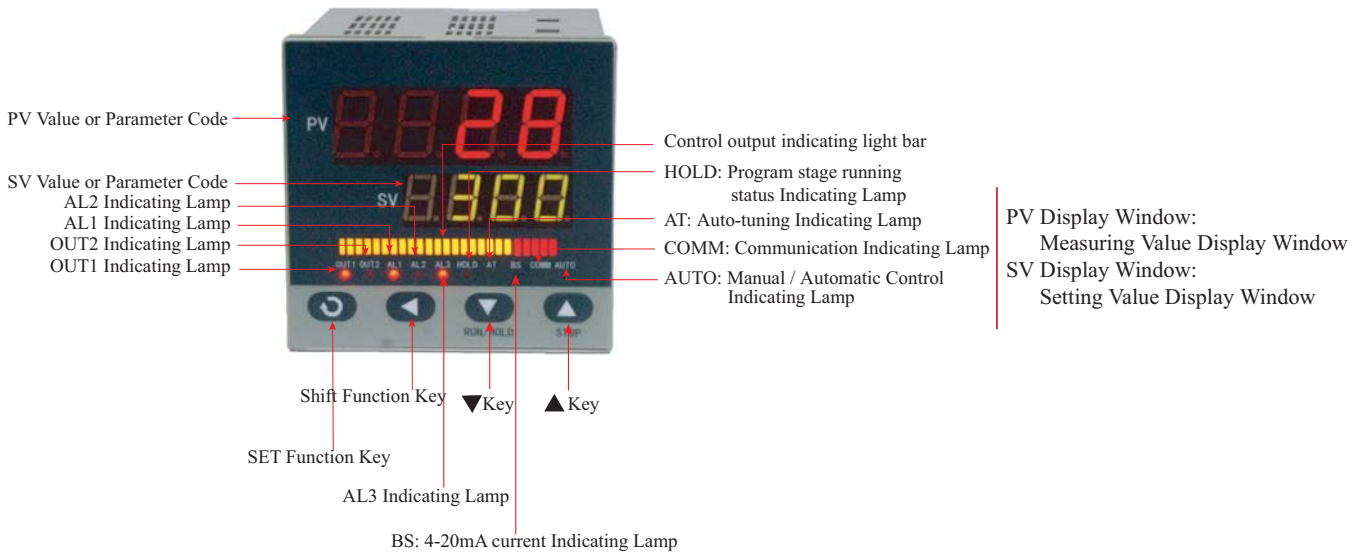

5. Panel Key Operation

- (1) SET key: In normal display status, press SET key to show setting menu, press SET key for a few seconds to show advanced setting menu.
- (2) ◀ key: press ◀ key to make the parameters to flicker, the parameters can be changed.
- (3) ▲, ▼ key: to change parameters in setting status.
- (4) In advanced setting menu, press SET key for a few seconds to quit the menu and back to normal display status.
- (5) In normal display status, press ◀ key for 3 second to start Auto-tuning function, at this moment AT indicating lamp turns on.

6. Operation Sequence

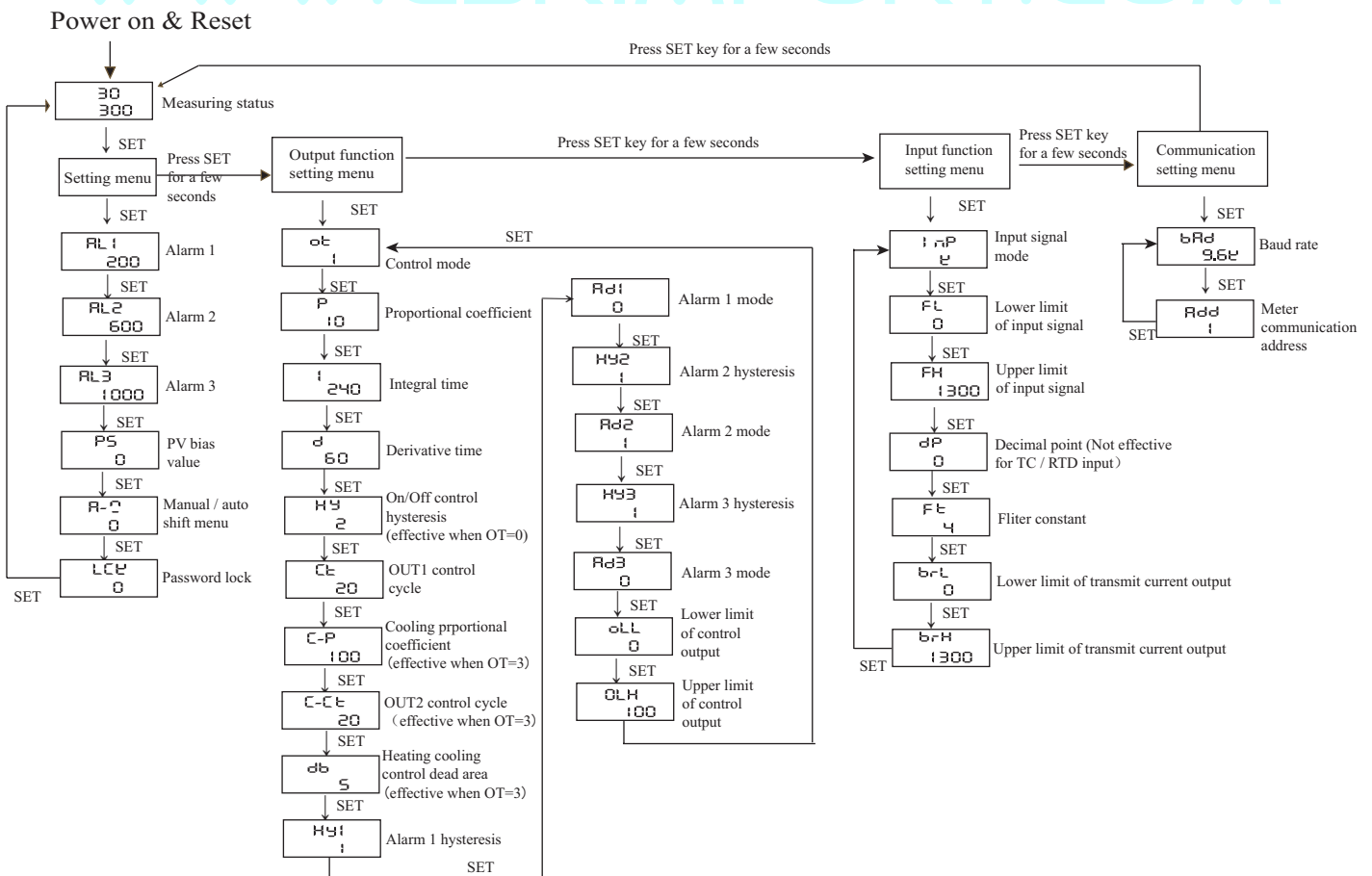

7. Program stage control setting

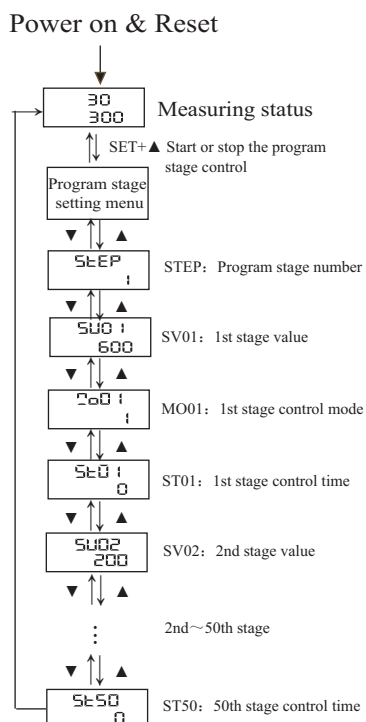

Program stage control setting method:

- There are total 50 program stages. For each stage, there are 3 settable parameters: SV, MO, ST.
- SV value is the object control value of a stage, for example, if SV is 200, the object control value of this stage is 200°C.
- MO value is the control mode of a stage.
 - MO value is -50~-1, it means the current stage will jump to the appointed stage, for example, if it is -45, it means the current stage will jump to stage no.45 directly, after the control of this stage is finished.
 - MO value is 0, it means the program stage control function will be stopped automatically when the program turns to this stage.
 - MO value is 1, it means when a stage control is running, the condition for jumping to next stage is setting time, when time is up, this stage will jump to the next appointed stage automatically.
 - MO value is 2, it means when a stage control is running, the condition for jumping to next stage is setting temperature, when the current temperature changes to the setting value, this stage will jump to the next appointed stage automatically.
- ST value is running time of a stage, the unit is minute. When MO is set to 1, the stage will run until ST is changed to 0. For example, SV=200, MO=1, ST=10, the current temperature is 30°C, this stage will run for 10 minutes. So the temperature will raise 17°C per minute in average. If MO=2, there is no time limit for temperature raise in this stage, when temperature reaches 200°C, the stage will jump to next one automatically.
- In normal display status, press SET key and ▲ key at the same time to show the parameter setting menu of program stage control.
- In normal display status, press SET key and ▼ key at the same time to run / stop program stage control function. HOLD lamp is on when program stage control is running. HOLD lamp is off when this control stops running.

Example: Here is a control process with below requirement, the relevant setting is on the right side:

- Temperature raises to 300°C, SV01=300, MO01=2; (No time limit)
- Temperature is keep at 300°C for 20 minute, SV02=300, MO02=1, ST02=20;
- Temperature falls to 150°C, SV03=150, MO03=2;
- Temperature is keep at 150°C for 60 minute, and then SV04=150, MO04=1, ST04=60;
- Program jumps to No.10 stage MO05= -10;
- Temperature falls to 25°C at No.10 stage SV10=25, MO10=2;
- Program control stops running at No.11 stage. MO11=0;

8. Menu

Parameter name	Indication	Setting range	Ex-factory setting
Setting menu			
AL1	Alarm 1 setting value	FL~FH	200
AL2	Alarm 2 setting value	FL~FH	600
AL3	Alarm 3 setting value	FL~FH	100
PS	Measured value amendment	-100~100	0
A_M	Manual / auto setting: 0: Manual; 1: half-auto (Start Auto-tuning manually) 2: auto (Start Auto-tuning automatically after power on)	0~2	1
LCK	If the units digit (4th digit from left to right) is 1, SV is prohibited to changed; if the tens digit (3rd digit) is 1, menu parameters are prohibited to changed.	0~9999	0
Output function setting menu			
OT	Control mode. 0: ON/OFF control; 1: Heating control; 2: Cooling control; 3: Heating & cooling control	0~3	1
P	Proportional coefficient (P=0: ON / OFF control)	0~9999	10
I	Integral time	0~3600	240
D	Derivative time	0~3600	60
HY	ON/OFF control hysteresis	0~1000	2
CT	OUT1 control cycle	0~250	20
C_P	Cooling proportional coefficient	1~200	100
C_CT	OUT2 control cycle	1~250	20
DB	Dead area for heating & cooling control	-100~100	5
HY1	Alarm hysteresis 1	0~1000	1
AD1	Alarm mode 1	0~3	0
HY2	Alarm hysteresis 2	0~1000	1
AD2	Alarm mode 2	0~3	1
HY3	Alarm hysteresis 3	0~1000	1
AD3	Alarm mode 3	0~3	0

OLL	Lower limit of control output	0~99	0
OLH	Upper limit of control output	1~100	100
Input function setting menu			
INP	Input signal type	Please refer to input signal table	K
FL	Lower display limit of input signal	Please refer to input signal table	0
FH	Upper display limit of input signal	Please refer to input signal table	1300
DP	Decimal point setting. Only effective for analog signal input	0~3	0
FT	Filter constant	1~250	4
BRL	Display for 4mA transmit current output	FL~FH	0
BRH	Display for 20mA transmit current output	FL~FH	1300
Communication setting menu			
BAD	Baud rate	4.8K, 9.6K, 19.2K	9.6K
ADD	Meter communication address	0~250	1

Alarm function table

Alarm code	Alarm mode	Alarm output (AL1, AL2 is independent with each other)
0	Direct (High limit)	
1	Inverse (Low limit)	
2	High relative to SV	
3	Low relative to SV	

9. Appearance & Mounting Dimension

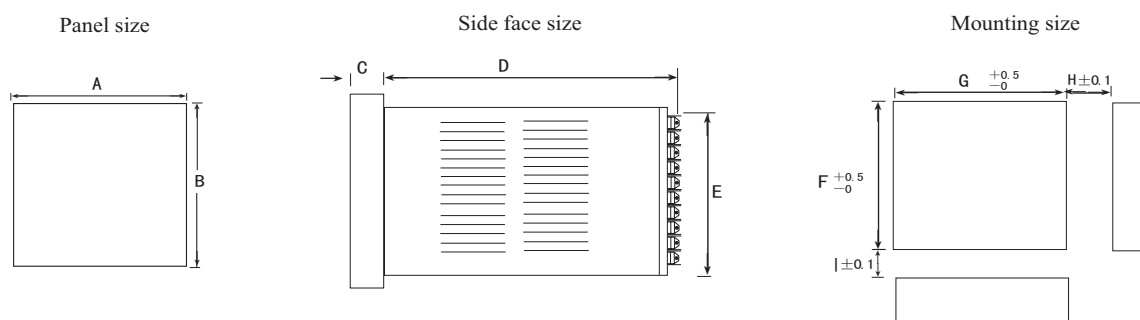

Model	A	B	C	D	E	F	G	H	I
AI808P-4	48	48	6	100	45	46	46	30	30
AI808P-6	48	96	9	100	89.5	91	46	30	30
AI808P-7	72	72	9	100	67	68	68	30	30
AI808P-8	96	48	9	100	45	46	91	30	30
AI808P-9	96	96	9	100	89.5	91	91	30	30

Unit: mm

10. Connection Drawing

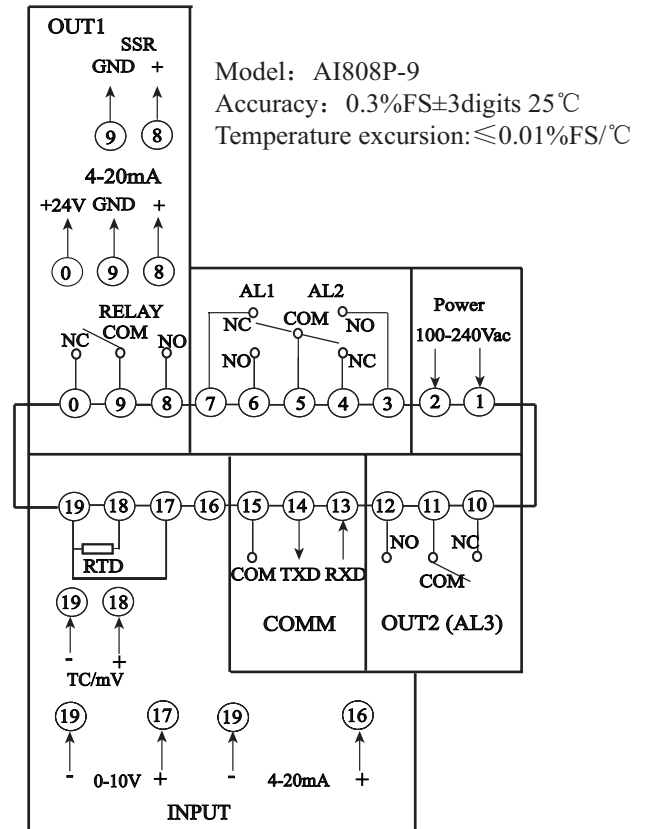
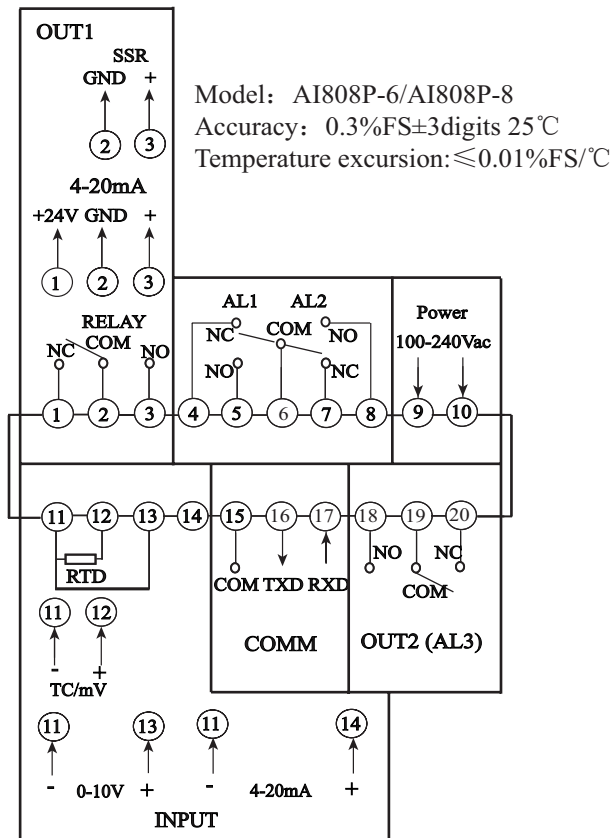

11. Simple Problem Shooting

Display Message	Shooting Method
Display HHHH	Input disconnect or over upper limit, please check input signal, FH value and ambient working temperature.
Display LLLL	Input disconnect or under lower limit, please check input signal, FL value and ambient working temperature.