

Intelligent Temperature Controller

User Manual

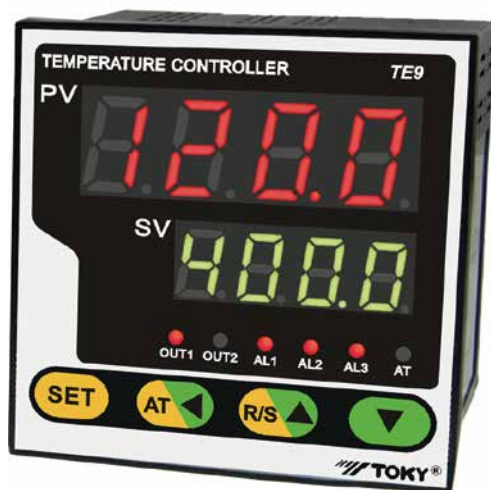

Features:

- Optional input signal types and models
- With many functions of measured display, control output, alarm output, analog output, RS485 communication, etc.
- Optional many types of PID arithmetic and with auto-tuning function.
- Using for industrial machinery, machine tools, measuring instruments.
- Economical and easy operation.

KKTEWE02C-A/0-20150826

The instruction explain instrument settings, connections, name and etc, please read carefully before you use the temperature controller. Please keep it properly for necessary reference.

■ Safe Caution

△ Warning

- 1) When the failure or abnormal of products lead to a system of major accidents, please set the proper protection circuit in the external.
- 2) Please don't plug in before completing all the wire. Otherwise it may lead to electric shock, fire, fault.
- 3) Not allow to use outside the scope of product specification, otherwise it may lead to fire, fault.
- 4) Not allow to use in the place where is inflammable and explosive gas.
- 5) Do not touch power terminal and other high voltage part when the power on, otherwise you may get an electric-shock.
- 6) Do not remove, repair and modify this product, otherwise it may lead to electric shock, fire, fault.

△ Caution

- 1) The product should not be used in a nuclear facility and human life associated medical equipment.
- 2) The product may occur radio interference when it used at home. You should take adequate countermeasures.
- 3) The product get an electric shock protection through reinforced Insulation. when the product is embedded in the devices and wiring, please subject to the specification of embedded devices.
- 4) In order to prevent surge occurs, when using this product in the place of over 30m indoor wiring and wiring in outdoor, you need to set the proper surge suppression circuitry.
- 5) The product is produced based on mounting on the disk. In order to avoid to touch the wire connectors, please take the necessary measures on the product
- 6) Be sure to observe the precautions in this manual, otherwise there is a risk of a major injury or accident.
- 7) When wiring, please observe the local regulation.
- 8) To prevent to damage the machine and prevent to machine failure, the product is connected with power lines or large capacity input and output lines and other methods please install proper capacity fuse or other methods of protection circuit.
- 9) Please don't put metal and wire elastic mixed with this product, otherwise it may lead to electric shock, fire, fault.
- 10) Please tighten screw torque according to the rules. If not, it may lead to electric shock and fire.
- 11) In order not to interfere with this products to dissipate heat, please don't plug casing around the cooling vent hole and equipment.
- 12) Please don't connect any unused terminal.
- 13) Please do the cleaning after power off, and use the dry cleaning cloth to wipe away the dirt. Please don't use desiccant, otherwise, it may cause the deformation or discoloration of the product.
- 14) Please don't knock or rub the panel with rigid thing.
- 15) The readers of this manual should have basic knowledge of electrical, control, computer and communications.
- 16) The illustration, example of data and screen in this manual is convenient to understand, instead of guaranteeing the result of the operation.
- 17) In order to use this product with safety for long-term, regular maintenance is necessary. The life of some parts of the equipments are by some restrictions, but the performance of some will change for using many years.
- 18) Without prior notice, the contents of this manual will be change. We hope these is no any loopholes, if you have questions or objections, please contact us.

△ Caution of Install & Connection :

1. Installation :

- 1) This product is used in the following environmental standards.
(IEC61010-1) [Overvoltage category II、 class of pollution 2]
- 2) This product is used in the following scope: surrounding environment, temperature, humidity and environmental conditions.
Temperature : 0 ~ 50°C; Humidity : 45 ~ 85%RH; Environment condition : Indoor warranty, The altitude is less than 2000m.
- 3) Please avoid using in the following places:
The place will be dew for changing temperature; with corrosive gases and flammable gas; with vibration and impact; with water, oil, chemicals, smoke and steam facilities with Dust, salt, metal powder; and with clutter interference, static electric and magnetic fields, noise; where has air conditioning or heating of air blowing directly to the site; where will be illuminated directly by sunlight; where accumulation of heat will happen caused by radiation.
- 4) On the occasion of the installation, please consider the following before installation.
In order to protect heat saturated, please ensure adequate ventilation space.
Please consider connections and environment, and ensure that the products below for more than 50mm space.
Please avoid to installed over the machine of the calorific value (Such as heaters, transformer, semiconductor operations, the bulk resistance).
When the surrounding is more than 50°C, please using the force fan or cooling fans. But don't let cold air blowing directly to the product.
In order to improve the anti - interference performance and security, please try to stay away from high pressure machines, power machines to install.
Don't install on the same plate with high pressure machine and the product.
The distance should be more than 200mm between the product and power line.

2.Cable caution :

- 1) Please use specified compensation wire in the place of TC input;Please use insulated TC if the measured device is heated metal.
 - 2) Please use the cable of lesser resistance in the place of RTD input,and the cable(3 wire) must be no resistance difference,but the total length is within 5m.
 - 3) In order to avoid the effect of noise,please put the input dignal away from meter cable,power cable,load cable to wiring.
 - 4) In order to reduce the power cables and the load power cables on the effect of this product,please use noise filter in the place where easy to effect.
- You must install it on the grounding of the disk if you use the noise filter,and make the wiring to be shortest between noise filter output side and power connectors.
- Don't install fuse and switch on the wiring of noice filter output side,otherwise it will reduce the effect of noise filter.
- 5) It takes 5s from input power to output.If there is a place with interlocking actions circuit signal,please use timer relay.
 - 6) Please use twisted pair with a shield for analog output line,to ensure the reliability of signal, if necessary.
 - 7) Please use twisted pair with a shield for remote RS485 communication cable,and deal with the shield on the host side earth, to ensure the reliability of signal.
 - 8) This product don't have the fuse; please set according to rated voltage 250V,rated current 1A if you need; fuse type:relay fuse.
 - 9) Please use the suitable screw force and crimp terminal.
The screw terminal size : M3X8 (with 6.8X6.8 square base)
Recommended tightening torque : 0.4N.m
Proper cables : 0.25 ~ 1.65mm single cable/multiple core cable
 - 10) Please don't put the Crimp terminal or bare wire part contact with adjacent connector.

Model

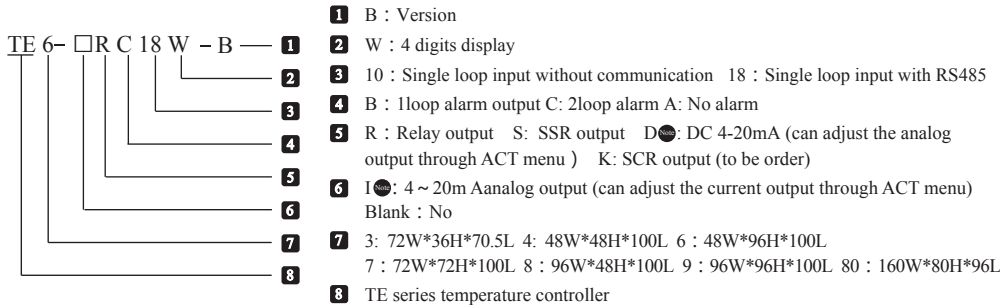

Please note the input signal type when you choose the model. 1st type:TC/RTD/mV/Rt ; 2nd type: mA/V.

Note: TE series is only one 4~20mA output function.For the size of 6、8、9,when relay output/SSR output is together with DC 4~20mA, it has discrimination with "I"; for example:IR,IS,etc,but it has not this type model for the size of 4、7.

Ordering Information

Model	Control output	Alarm	Analog 4 ~ 20mA	RS485
TE□-IRC18W	Relay / 4 ~ 20mA	2	Yes	Yes
TE□-ISC18W	SSR / 4 ~ 20mA	2	Yes	Yes
TE□-DC18W	4 ~ 20mA	2	Multiplex with main control	Yes
TE□-RB10W	Relay	1	No	No
TE□-SB10W	SSR	1	No	No

□ : Optional dimensions

Specifications

1、Electrical parameters:

Sample rate	2SPS
Relay capacity	AC 250V /3A Life of rated load>100,000 times
Power supply	AC/DC 100 ~ 240V(85-265V)
Power consumption	< 6VA
Environment	Temperature of indoor : 0 ~ 50°C no condensation , Humidity : < 85%RH , altitude<2000m
Storage environment	-10 ~ 60°C, no condensation

SSR output	DC 24V pulse level , load<30mA
Current output	DC 4 ~ 20mA load<500Ω , Temperature drift 250PPM
Communication port	RS485 port Modbus-RTU proccotol, max input 30units
Insulation impedance	Input, output, power cabinet > 20MΩ
ESD	IEC/EN61000-4-2 Contact ±4KV /Air ±8KV perf.Criteria B
Pulse traip anti-interference	IEC/EN61000-4-4 ±2KV perf.Criteria B
Surge immunity	IEC/EN61000-4-5 ±2KV perf.Criteria B
Voltage drop & short interruption immunity	IEC/EN61000-4-29 0% ~ 70% perf.Criteria B
Dielectric strength	Signal input & output & power 1500VAC 1min , below 60V Low voltage circuit between DC500V,1min
Total weight	About 400g
Shell material	The shell and panel frame PC/ABS (Flame Class UL94V-0)
Panel material	PET(F150/F200)
Power-off data protection	10 years , times of writing: 1 million times
Protection level of panel	IP65(IEC60529)
Safety Standard	IEC61010-1 Overvoltage category II , pollution level 2 , levelII(Enhanced insulation)

2、Measured signal specifications :

Input type	Symbol	Measuring range	Resolution	Accuracy	Input impedance/auxiliary current	Communication parameter code
K	Ǝ	-50 ~ 1200	1°C	0.5%F.S±3digits	> 500kΩ	0
J	Ǝ	0 ~ 1200	1°C	0.5%F.S±3digits	> 500kΩ	1
E	Ǝ	0 ~ 850	1°C	0.5%F.S±3digits	> 500kΩ	2
T	Ǝ	-50 ~ 400	1°C	0.5%F.S±2°C	> 500kΩ	3
S	Ǝ	-10 ~ 1600	1°C	0.5%F.S±1°C	> 500kΩ	4
PT100	Ǝ	-200 ~ 600	0.2°C	0.5%F.S±3digits	0.2mA	5
CU50	Ǝ	-50 ~ 150	0.2°C	0.5%F.S±3°C	0.2mA	6
CU100	Ǝ	-50 ~ 150	0.2°C	0.5%F.S±1°C	0.2mA	7
0 ~ 50mV	Ǝ	-1999 ~ 9999	12bit	0.5%F.S±3digits	> 500kΩ	8
0 ~ 400Ω	Ǝ	-1999 ~ 9999	12bit	0.5%F.S±3digits	0.2mA	9
* 4 ~ 20mA	Ǝ	-1999 ~ 9999	12bit	0.5%F.S±3digits	100Ω	10
* 0 ~ 10V	Ǝ	-1999 ~ 9999	12bit	0.5%F.S±3digits	>1MΩ	11

* Please note when you choose the model

3、Isolation diagram

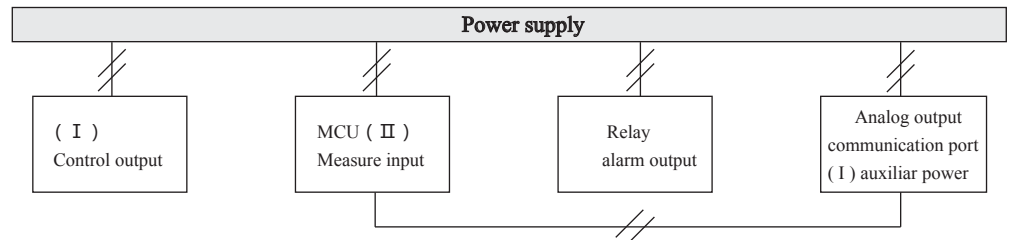

“//” : Isolation

Note : When the auxiliary power supply between (I) & (II) is as the power supply of external sensor, if the sensor is non-isolated, it does not isolate.

■ Name of universal panel

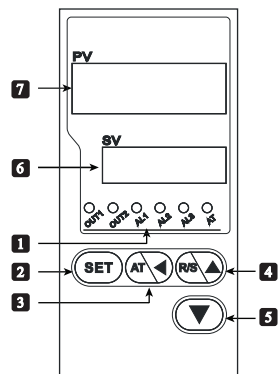

No	Symbol	Name	Function
1	OUT1	OUT1 indicator light(red)*	Main control output indicator light, it light when the output is ON
	OUT2	OUT2 indicator light(red)*	Cooling output indicator light,it light when the output is ON
	AL1	Alarm1# indicator light(red)	1st loop alarm output indicator light,alarm output with light,no alarm output without light.
	AL2	Alarm2# indicator light(red)	2nd loop alarm output indicator light,alarm output with light,no alarm output without light.
	AL3	Alarm3# indicator light	AL3 : This product has no the function
	AT	AT indicator light(green)	Auto-tuning indicator light,it show setting state when it light
2		SET function key	Menu key/ensure key,to use enter or back to modified mode or ensure/save parameters
3		Shift/AT key	Activation key/shift key/AT setting key,long press to enter or back to auto-tuning under the measure control mode.
4		Add key/R/S	Add key,long press it can reach switch of RUN/STOP mode under the measure control mode.
5		Reduce key	Reduce key
6	SV	Display window (green)	Setting value/parameters display window,display "STP" =stop control
7	PV	Display window (red)	measured value/parameters code display window

*: Size "3" is green color.

■ Dimension and installation size

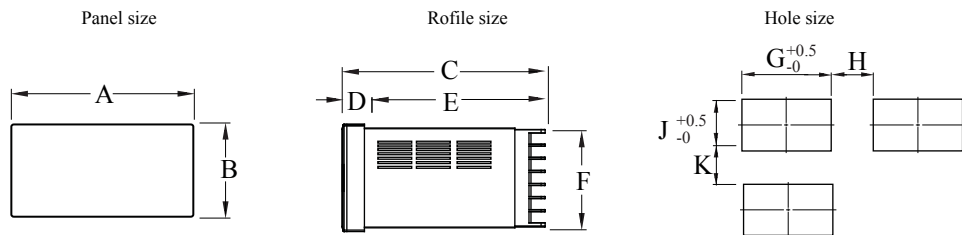

Model	A	B	C	D	E	F	G	H(Min)	J	K(Min)
3:(72*36)	72	36	70.5	6.5	64	32	68	25	33	25
4:(48*48)	48	48	97.5	6.5	91	45	45.5	25	45.5	25
6:(96*48)	48	96	97.5	9	88.5	89.5	45	25	92	25
7:(72*72)	72	72	97.5	9	88.5	67	67.5	25	67.5	25
8:(48*96)	96	48	97.5	9	88.5	44.5	92	25	45	25
9:(96*96)	96	96	97.5	9	88.5	91.5	92	25	92	25
80:(80*160)	160	80	96	13	83	75.5	155.5	30	76	30
16:(160*80)	80	160	96	13	83	155	76	30	155.5	30

■ Operation & menu

1、Operation process & method measure control mode

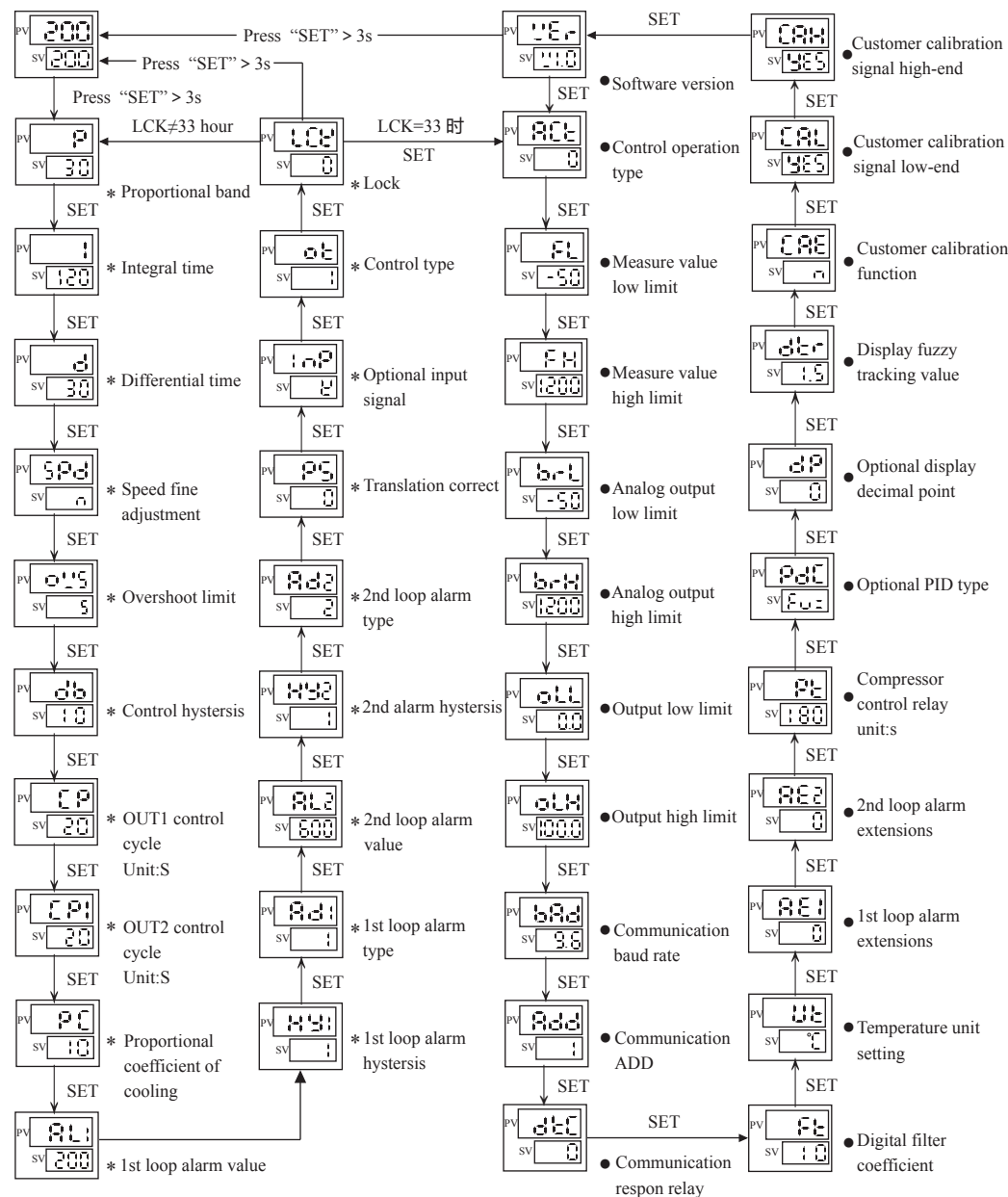

"*" : Normal menu parameters

"●" : Project menu parameters

- a. In the normal measure control mode and after power-on, long press **SET** key more than 3s to enter the menu parameters checking mode.
- b. In the menu checking mode, press **SET** key to check the menu parameters recurrently.
- c. In the menu checking mode, press **↔** to flash the current menu parameters, to enter the parameter modify mode, and it can move one position when you press each short time, in this cycle.
- d. In the menu modifying mode, press **▲** or **▼** key once to add or reduce one of flashing data.
- e. In the menu modifying mode, after the modification, press **SET** to save the modified parameter, and exit to menu checking mode.
- f. In the normal measure control mode, press **↔** to enter SV value modifying status. The way of modifying SV value is same as that of modifying menu parameters.
- g. In the normal measure control mode, long press **↔** more than 3s to enter auto-tuning state. During auto-tuning, PV value needs to be lower than SV value.
- h. In the normal measure control mode, long press **▲** key more than 3s to enter or back to control mode.

2. Menu description

No.	Menu name	Description	Set range	Factory set
1	PV	Measuring display value, it will flash or display LLLL/HHHH when the value overflow measure range.	Refer to measured signal table	No
2	SV	Control item setting value	FL ~ FH	200
3	P	Proportional band, the lower of setting value, the faster of system heating or the more slowly. Increasing proportional band can reduce vibration, but it will add the control bias vibration. Reducing proportional band can reduce control bias, but it will lead to vibration	0 ~ 9999	30
4	I	The lower of integral time value, the stronger of integral action, the more tendency to eliminate and deviation of a set value. If integral action is weak, it maybe can not eliminate the deviation. Unit: S	0 ~ 9999	120
5	D	Differential time, reduce the effect of differential time to a proper value, which can prevent the system oscillation. The higher value, the stronger function of differential. Unit: s	0 ~ 9999	30
6	SPD	Control speed fine tuning, optional 0(N) no function, 1(slow), 2(ss) medium slow, 3 (SSS) very slow , 4 (F) fast , 5 (FF) medium fast , 6 (FFF) express	0 ~ 6	N
7	OVS	Overshoot limit, in the process of PID control, when PV > SV + OVS, it force off output; The lower value, the lower PID adjusted range, the worse control stability; please set a proper value according actual state.	0 ~ 9999	5
8	DB	Bit control backlash (negative backlash bit control) or cooling control and compressor cooling control dead zone. please change the value according to decimal position, when you change INP type.	0 ~ 1000	10
9	CP	OUT1 control cycle, 1: SSR control output, 4-200: relay control output. Unit: s	1 ~ 200	20
10	CP1	OUT2 control cycle, cooling relay output cycle. Unit: s	4 ~ 200	20
11	PC	OUT2 cooling proportionality coefficient, the higher of value, the stronger of cooling	1.0 ~ 100.0	10.0
12	AL1	1st loop alarm value, note: the minus is dealt as absolute value when it is as a deviation value .	FL ~ FH	200
13	HY1	1st loop alarm backlash value	0 ~ 1000	1
14	AD1 (1)	1st loop alarm type, note: the value should set 0 when 1st loop alarm is as OUT2; Set AD2 to 0 when setting value > 6. Otherwise it will close alarm function when it is 0.	0 ~ 12	1
15	AL2	2nd loop alarm value, note: the minus is dealt as absolute value when it is as a deviation value .	FL ~ FH	600
16	HY2	2nd loop alarm backlash value	0 ~ 1000	1
17	AD2 (1)	2nd loop alarm type, note: the value should set 0 to close alarm function when the AD1 > 6.	0 ~ 6	2
18	PS	Translation correction value, display value = actual measured value + translation correction value	-1999 ~ 9999	0

19	INP	Optional input measured signal type: refer to input signal parameters table. Note: it need to change the relevant parameters after changing.	0 ~ 10	0
20	OT	Control type: 0: ON/OFF control; 1: PID heating control; 2: compressor cooling control; 3: PID & cooling control, it should set the AD1 to 0, then OUT2 can operate.	0 ~ 3	1
21	LCK	Lock function: 0001: SV value can not be changed; 0010: menu setting value only can check not change. It can enter project menu with 0033 in the process of checking menu.	0 ~ 9999	0
22	ACT	Control execution type: 0: relay/SSR output; 1: single SSR output control 2: 4 ~ 20mA output control, please set according selected meter 3: TE4, TE7 can set 3 and change 4-20mA to analog output.	0 ~ 2/0~3	0
23	FL	Measure range low limit, the setting value must be less than measure range high limit	Refer to measured signal parameter table	-50
24	FH	Measure range high limit, the setting value must be more than measure range low limit.	Refer to measured signal parameter table	1200
25	BRL	Analog range high limit, note: the value is reverse analog output when it higher than analog range low limit.	FL ~ FH	-50
26	BRH	Analog range high limit, note: the value is reverse analog output when it less than analog range low limit.	FL ~ FH	1200
27	OLL	Output low limit, limit the output low limit current amplitude. Setting value must be less than high limit setting	-5.0 ~ 100.0	0
28	OLH	Output high limit, limit the output high limit current amplitude. Setting value must be more than low limit setting	0.0 ~ 105.0	100
29	BAD	RS485 communication baud rate 0 (4.8) : 4800 ; 1 (9.6) : 9600	0 (4.8) , 1 (9.6)	9.6
30	ADD	Communication ADD	0 ~ 255	1
31	DTC	Sequenced transport of communication data and setting 000 of respon relay; 1st is function reserve, 2nd is byte sequenced exchange, 3rd is respon relay, it can set 0~9 to 10~100ms.	Refer to communication protocol note②	0
32	FT	PV filter coefficient of digital filter, the higher of value, the stronger of filter function	0 ~ 255	10
33	UT	Temperature unit: °C: degrees Celsius F : Fahrenheit, note: the unit is only for temperature measure signal.	25 (°C) 26 (°F)	25 (°C)
34	AE1(2)	1st loop alarm extensions	0 ~ 5	0
35	AE2(2)	2nd loop alarm extensions	0 ~ 5	0
36	PT	Starting relay time of compressor, unit: s	0 ~ 9999	180
37	PDC	Optional PID type 0(FUZ) : Advanced fuzzy PID arithmetic ; 1(FCT): Single prediction PID arithmetic; 2(STD) : normal PID arithmetic	0 ~ 2	FUZ
38	DP	Decimal point setting, it will affect in the line signal input.	0 ~ 3	0
39	DTR	PV fuzzy tracking value, it can get a stable control display value in some place where is suitable to set the value. The value is unrelated with actual measured value. Note: when the alarm setting value is equal with SV setting value after setting the value, operation of alarm output will subject to actual measured value. Setting 0 to close the function. Temperature unit: F/°C Line signal input unit: engineering work Digits	0.0 ~ 2.0/0 ~ 20	1.5/15

40	CAE	User auto-calibrating enable function,this parameter is only for use of input signal expect TC/RTD;Y:user of enable auto-calibrating parameters N:user who don't use enable auto-calibrating parameters	0 (N) , 1 (Y)	N
41	CAL	Operation of user auto-calibrating low limit input,it is starting,when the YES flash after signal input add the low-side signal. It can calibrate input signal low-side when it display OK after entering.	YES/OK	YES
42	CAH	Operation of user auto-calibrating low limit input,it is starting,when the YES flash after signal input add the high-side signal. It can calibrate input signal high-side when it display OK after entering.	YES/OK	YES
43	VER	Display the software version	_____	_____

(1) Alarm parameters and output logic diagram: Symbol description : “☆” means HY , “▲” means alarm value , “△” means SV value

No.	Type	Alarm output (AL1、AL2 is independent of each) Image : the hatched section means the alarm actio
1	High limit absolute value alarm	
2	Low limit absolute value alarm	
3	※High limit deviation value alarm	
4	※Low limit deviation value alarm	
5	※High/low limit deviation value alarm	
6	※High/low limit interval value alarm	

No.	Type	The following two sets of alarm parameters(AL1、AL2) used in combination,AL1 alarm output,AD2 must set to 0
7	High/low limit absolute value alarm	
8	※High/low limit deviation value alarm	
9	※Alarm between high limit absolute value and low limit deviation value .	
10	※Alarm between high limit deviation value and low limit absolute value.	
11	High/low absolute value alarm	
12	※High/low limit deviation alarm	

※When the alarm value with deviation alarm set to a negative number,it will deal with it as an absolute value.

(2) Alarm extension function table

AE1/AE2 value		Alarm handling when show the HHHH/LLLL	Remark
Power alarm does not inhibit	0	The state when alarm keep HHHH/LLLL in previous time	As long as meet the requirement of alarm, alarm output
	1	Forced alarm output	
	2	Forced alarm close	
Power alarm inhibit	3	The state when alarm keep HHHH/LLLL in previous time	Before the PV value reach the set value in the first time ,the alarm does not output.
	4	Forced alarm output	
	5	Forced alarm close	

■ Key function operation

1. Monitoring mode operation

- 1) Under the measure mode,press into monitoring mode;and on the SV window display“STP”. Long Press to back.
- 2) It can alter SV value and switch operation even displaying STP.
- 3) Under the monitoring mode,host control output will stop or set min output except alarm output and analog output.

2. PID Parameter identification and auto-tuning operation:

- 1) The factory default PID parameters usually does not apply to usage occasion;please using auto-tuning function to get a suitable PID parameter.
- 2) The meter will enter control output since the power input, now,you can set the monitoring mode to avoid to affect the effect of auto-tuning function,or switch off the power of control output load.No matter how to operate, it should guarantee the set value greater than the current measured value and drop the bigger the better.
- 3) In order to avoid the effect deu to alarm interlocking output,please set the proper alarm value,or remove the alarm effect.
- 4) Set PID type and SV value;the factory default is PID with fuzzy.
- 5) Set to PID control,please set the output to a proper range if it has OLL & OLH output limit;factory default is OLL=0%,OLH=100%.
- 6) Under the condition of PV value at normal room temperature,please back to monitoring mode or input the load power,and long press enter auto-tuning mode, now, AT indicator will shine.
- 7) Auto-tuning will take the time,in order not to affect auto-tuning result,please don't change the parameters or power-off.
- 8) PID parameters will auto update when AT light is out and auto back auto-tuning mode.This monment,it will auto control exactly.
- 9) It will abort the auto-tuning when you long press key,measure beyond the scope,display abnormally,swith to “STP”,power-off in the process of auto-tuning.

10) Note: In the place with output limit,it can't get the best PID parameters even with the auto-tuning.

11) Experienced users can set a proper PID parameter according to their experience.

3. PID & Cooling control operation

- 1) PID control act on host control output OUT1 ; Cooling control act on OUT2.
- 2) AL1 alarm function & OUT2 can reuse,please set AD1 to 0 when using the cooling control;but the 1st alarm function can't work after setting.
- 3) Please set the control type OT to 3.
- 4) Please set the cooling start offset to a value great than 5,to ensure the cooling would not affect the PID control impact.
- 5) Please change the cooling control cycle to a proper value,and change the cooling scaling factor to a a proper value.
- 6) When PV value > SV+DB value,the cooling control start to effect;the bigger value of PV,the longer output time of OUT2

4.Signal linear auto-tuning function operation

- 1) Set up the INP type,and ensure one of inputs(0~50mV、RT(0~400Ω)、4~20mA and 0~10V)
- 2) Add the input signal to a proper input channel.
- 3) Enter menu low-limit to calibrate CAL,press to flash“YES”;and set the input signal to min value and input to meter.
- 4) When “YES”is flashing,and the min value of signal has input to meter,please press “SET”to ensure and save the calibrating value.
- 5) After calibrating low-limit,enter the high limit to calibrate CAH in menu,and flash “YES”.
- 6) Set the input signal to max value to meter,and press “SET”to ensure and save the calibrating value when the “YES”is flashing.
- 7) After calibrating,it can enter CAE,and change “N”to “Y”then it can use calibrating value,or it will use the factory default value.
- 8) The linear signal value of high-limit input should not great than the inout standard value range ±10%.
- 9) If you're not satisfied with the calibrating result,you can reset.

■ Connections

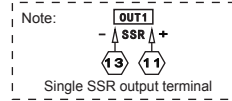
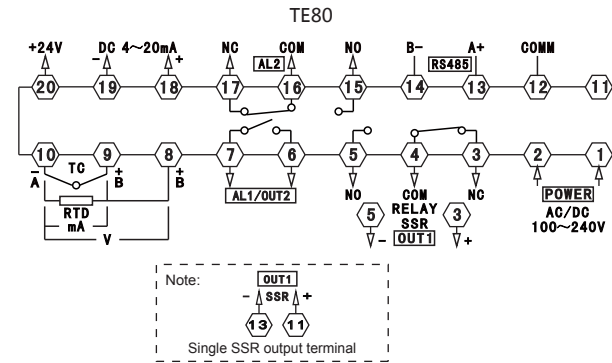
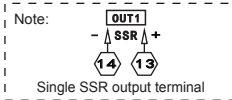
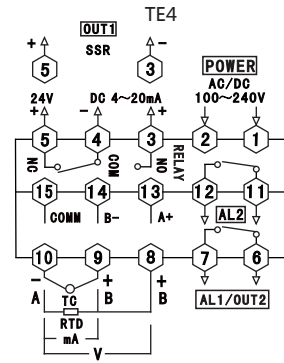
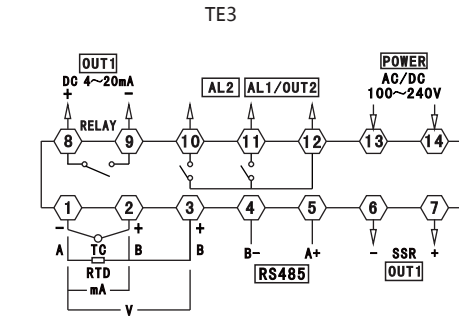

Note: If there is any change, please subject to the drawing on the meter

■ Methods of simple fault

Display	Methods
LLLL/HHHH	Checks whether the input disconnection and whether normal of FH value, FL value, working environment temperature and whether input signal is selected correctly.

■ Communication protocol

Meter use Modbus RTU to do RS485 half-duplex communication. Reading function ID: 0x03, writing function ID: 0x10/0x06. The meter use 16 digits CRC to check and will not feedback any information of checked error.

Data frame format:

Start bit	Data bit	Stop bit	Check bit
1	8	1	No

Handling of abnormal communication :

If there is abnormal response , put the function ID on the top position 1. For example: Host request the function ID 0x03, and the response function ID from client should be 0x83.

Error code:

0x01---Illegal function: the function ID sent from host is not support by meter.

0x02---Illegal address: the register address designated by host beyond the address range of meter.

0x03---Illegal data: the writing data sent from host beyond the writing range of meter.

Communication cycle :

Communication cycle is the time from host request to client back to data: communication cycle = time of request + time of client response + time of relay + time of back

eg: 9600 Baud rate: communication cycle of single measured data > 250ms.

1、Read register

For example: Host reads integer SV (set value 200)

The ADD code of SV is 0x2000, because SV is integer (2 byte), seizes 1 data register. The memory code of decimal integer 200 is 0x00C8

Note: It should read DP value or ensure DP value in first to ensure the decimal point when reading data, and need to transform the reading data to get the actual value. Conversely, it should transform the data to corresponding ratio before writing the data in meter.

Host request (Read multi-register)							
1	2	3	4	5	6	7	8
Meter ADD	Function ID	Start ADD High bit	Start ADD Low bit	Data byte Length/high bit	Data byte Length/low bit	※CRC code low bit	※CRC code high bit
0x01	0x03	0x20	0x00	0x00	0x01	0x8F	0xCA

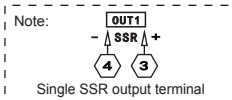
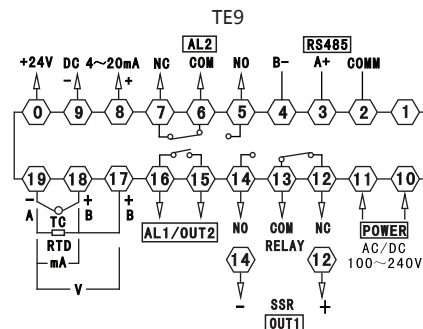
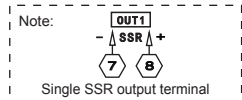
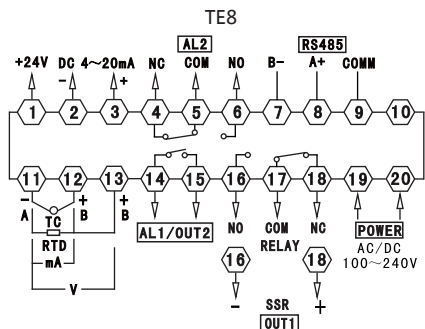
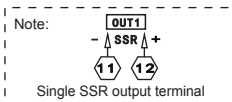
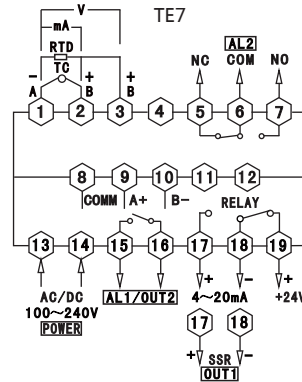
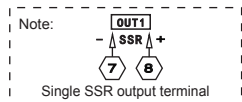
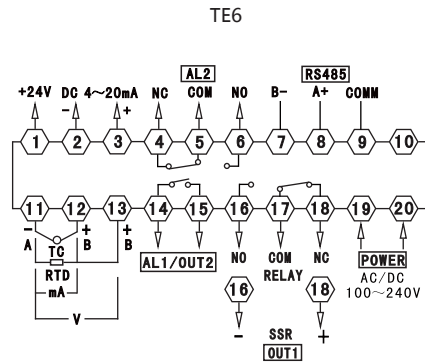

Client normal answer(Read multi-register)						
1	2	3	4	5	6	7
Meter ADD	Function ID	Data byte number	Data high bit	Data low bit	※CRC code low bit	※CRC code high bit
0x01	0x03	0x02	0x00	0xC8	0xB9	0xD2

Function ID abnormal answer: (For example:host request ADD is 0x2011)

Client abnormal answer(Read multi-register)				
1	2	3	8	9
Meter ADD	Function ID	Error code	※CRC code low bit	※CRC code high bit
0x01	0x83	0x02	0xC0	0xF1

2、Write multi-register

For example:Host write SV with 0x10 function (setting value 150)

ADD code of SV is 0x2000,because SV is integer(2 dyte),seizes 1 data register.The hexadecimal memory code of decimal integer 150 is 0x0096.

Host request (write multi-register)										
1	2	3	4	5	6	7	8	9	10	11
Meter ADD	Function ID	Start ADD High bit	Start ADD Low bit	Data byte Length/ high bit	Data byte Length/ low bit	Data byte Length	Data high bit	Data low bit	※CRC code low bit	※CRC code high bit
0x01	0x10	0x20	0x00	0x00	0x01	0x02	0x00	0x96	0x07	0xFC
Client normal answer (write multi-register)										
1	2	3	4	5	6	7	8			
Meter ADD	Function ID	Start ADD High bit	Start ADD Low bit	Data byte Length/ high bit	Data byte Length/ low bit	※CRC code low bit	※CRC code high bit			
0x01	0x10	0x20	0x00	0x00	0x01	0x0A	0x09			

Host write SV with 0x06 function (setting value 150)

Host request (write single-register)							
1	2	3	4	5	6	7	8
Meter ADD	Function ID	ADD High bit	ADD Low bit	Data high bit	Data low bit	※CRC code low bit	※CRC code high bit
0x01	0x06	0x20	0x00	0x00	0x96	0x02	0x64
Client normal (write single-register)							
1	2	7	4	5	6	7	8
Meter ADD	Function ID	ADD High bit	ADD Low bit	Data high bit	Data low bit	※CRC code low bit	※CRC code high bit
0x01	0x06	0x20	0x00	0x00	0x96	0x02	0x64

Data location error response:(For example:Host request the ADD index is 0x200F)

Client abnormal answer (write multi-register)				
1	2	3	8	9
Meter ADD	Function ID	Error code	※CRC code low bit	※CRC code high bit
0x01	0x90	0x02	0xCD	0xC1

Address Mapping Table of Meter Parameters

No.	ADD mapping	Variable name	Register	Read/write	Remark
1	0x2000	Set value SV	1	R/W	
2	0x2001	1st loop alarm AL1	1	R/W	
3	0x2002	1st loop alarm backlash HY1	1	R/W	
4	0x2003	2nd loop alarm AL2	1	R/W	
5	0x2004	2nd loop alarm backlash HY2	1	R/W	
6	0x2005	Display low limit FL	1	R/W	
7	0x2006	Display high limit FH	1	R/W	
8	0x2007	Analog output low limit BRL	1	R/W	
9	0x2008	Analog output high limit BRH	1	R/W	
10	0x2009	Control output low limit OLL	1	R/W	Default with 1 decimal point
11	0x200A	Control output high limit OLH	1	R/W	Default with 1 decimal point
12	0x200B	Overshoot limit OVS	1	R/W	
13	0x200C	Heat & Cool control dead zone DB	1	R/W	
14	0x200D	Proportional coefficient of cooling PC	1	R/W	Default with 1 decimal point
15	0x200E	Translation correct PS	1	R/W	
16	0x200F	Dispaly fuzzy tracking value DTR	1	R	Engineering work without decimal point
17	0x2010	Measure value PV	1	R	
Reserve					
18	0x2100	1st loop alarm type AD1	1	R/W	
19	0x2101	2nd loop alarm type AD2	1	R/W	
20	0x2102	1st loop alarm extended mode AE1	1	R/W	
21	0x2103	2nd loop alarm extended mode AE2	1	R/W	
22	0x2104	Control type OT	1	R/W	
23	0x2105	Control type ACT	1	R/W	
24	0x2106	RUN STOP operation	1	R/W	1 : RUN 2 : STP 3 : Run auto-tuning 4 : Stop auto-tuning

25	0x2107	Decimal point DP	1	R/W	
26	0x2108	Unit display UT	1	R/W	25 (°C) 26 (°F)
27	0x2109	Filter constants FT	1	R/W	
28	0x210A	Proportional coefficient P	1	R/W	No decimal point
29	0x210B	Integral time I	1	R/W	No decimal point
30	0x210C	Differential time D	1	R/W	No decimal point
31	0x210D	Control speed fine-tune SPD	1	R/W	
32	0x210E	Heating control cycle CP	1	R/W	No decimal point
33	0x210F	Cooling control cycle CP1	1	R/W	No decimal point
34	0x2110	Cooling relay time PT	1	R/W	No decimal point
35	0x2111	Optional input signal INP	1	R/W	Refer to measured signal table
36	0x2112	Meter address ADD	1	R/W	
37	0x2113	Communication baud rate BAD	1	R	
38	0x2114	Communication delay setting DTC	1	R	Note ②
39	0x2115	PID arithmetic type PDC	1	R	
40	0x2116	Lock key LCK	1	R	
41	0x2117	Meter name	1	R	
42	0x2118	Output state	1	R	Note ①

R : Read ; R/W : Read/write

Note①: : In the measuring state indication,it means operation when the data position is 1,but it means no operation when it is 0.

D7	D6	D5	D4	D3	D2	D1	D0
STOP	HHHH	LLLL	AT	AL2	AL1	OUT2	OUT1

Note②: Sequenced transport and respon relay of DTC communication data

DTC :

※16 digits CRC check code get C program

```

unsigned int Get_CRC(uchar *pBuf, uchar num)
{
    unsigned i,j;
    unsigned int wCrc = 0xFFFF;
    for(i=0; i<num; i++)
    {
        wCrc ^= (unsigned int)(pBuf[i]);
        for(j=0; j<8; j++)
        {
            if(wCrc & 1){wCrc >>= 1; wCrc ^= 0xA001; }
            else
                wCrc >>= 1;
        }
    }
    return wCrc;
}

```